

# Shenzhen Leadtek Electronics Co.,Ltd

## PRODUCT SPECIFICATION

### TFT-LCD MODULE

**Module No:** LTK133FTBGT23-V0

Preliminary Specification

Approval Specification

Designed by	Checked by	Approved by
<i>jona</i>	<i>Jams</i>	<i>lan</i>

### Final Approval by Customer

Approved by	Comment

※The specification of "TBD" should refer to the measured value of sample . If there is difference between the design specification and measured value, we naturally shall negotiate and agree to solution with customer.

## 2.General Specifications

N0	Item	Specification	Unit	Remark
1	LCD Size	TFT"13.3	inch	-
2	Panel Type	IPS	-	-
3	Display Resolution	1920 x RGB x1080	pixel	-
4	Display mode	Normally Black	-	-
5	Display colors	16.7M	Colors	8Bit
6	Viewing Direction	ALL	-	-
7	CG+LCM Module size	359.00(H)x240.00(V)x7.70(T)	mm	Note
8	Active Area	293.76(H)x165.24(V)	mm	Note
9	Pixel Pitch	0.153(W)x0.153(H)	mm	-
10	Weight	810.1	g	-
11	Driver IC	-	bit	-
12	Light Source	White LED	-	-
13	Interface	EDP	-	-

## 3.EXTERNAL DIMENSIONS

# Front View

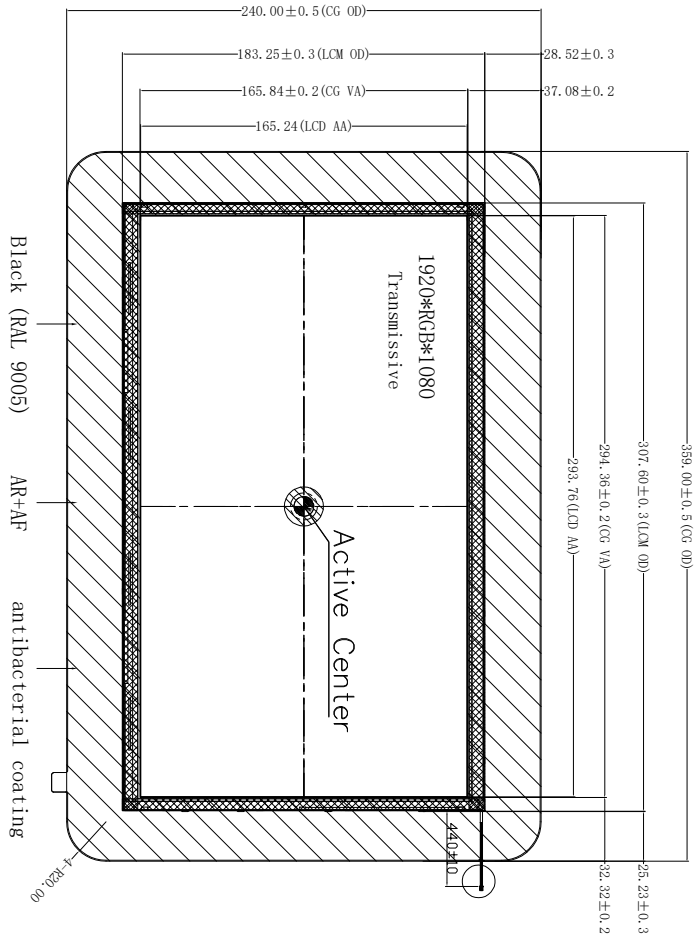

# Side View

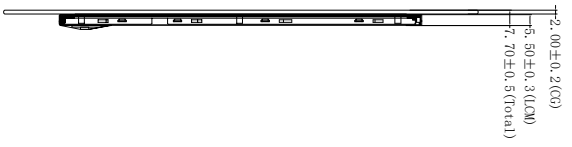

# Back View

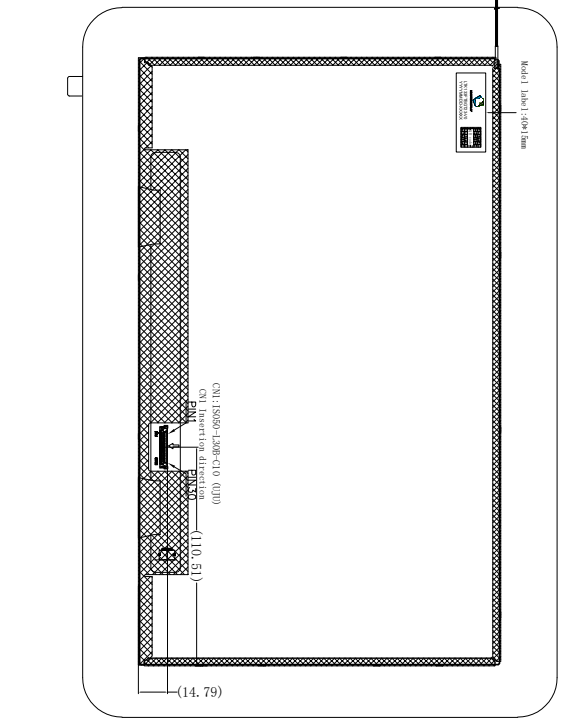

Pin No.	Pin Description
1	CABC_EN
2	GND
3	LANE1_N
4	LANE1_P
5	GND
6	LANE0_N
7	LANE0_P
8	GND
9	AUX_CH_P
10	AUX_CH_N
11	GND
12	LDC_VCC
13	LCD_VCC
14	LCD_TEST
15	GND
16	GND
17	HPD
18	BL_GND
19	BL_GND
20	BL_GND
21	BL_GND
22	BL_ENABLE(OC)
23	BL_PWM(OC)
24	MSCL
25	MSDA
26	BL_POWER(OC)
27	BL_POWER(OC)
28	BL_POWER(OC)
29	BL_POWER(OC)
30	NC

1. Silkscreen color: PANTONE Black (RAL 9005)
2. Break all sharp edges.
3. Material: Tempered glass (optiwhite), Surface AR+AF treatment.
4. Thickness = 2mm.
5. Surface hardness: 6H

### Notes:

1. Display : 13.3", TFT
2. Resolution: 1920xRGBx1080
3. LCD Viewing Direction: All
5. Display Mode: Normally Black
7. LCM+CG Brightness: 430cd/m<sup>2</sup>(TYP)
6. unmark Tolerance:±0.2
8. OPERATING TEMP: -0° C~+50° C
9. STORAGE TEMP: -20° C~+60° C
10. "∗" The focus is on controlling the size
11. Requirements on Environmental Protection: ROHS

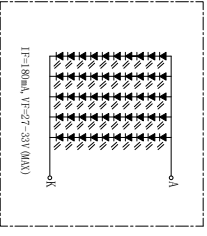
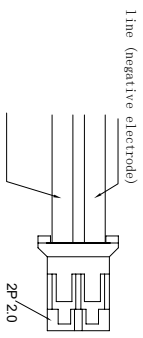

REV	DESCRIPTION	DATE	NAME
3			
2			
1			
0	NEW	2026.01.15	kevin

  
**Shenzhen Leadtek Electronics Co., Ltd**

SCALE: 1/1	UNIT: mm	PAGE: 1/1	Approve	Check	Drawn
Part No.: LTK133FTBG1P23	VER: V0		Jams	Jona	kevin
Customer No.:					

## 4.0 GENERAL DESCRIPTION

### 4.1 Introduction

LTK133FTBGT23-V0 is a color active matrix TFT LCD module using amorphous silicon TFT's(Thin Film Transistors) as an active switching devices. This module has a 13.3 inch diagonally measured active area with Full-HD resolutions (1920 horizontal by 1080 vertical pixel array). Each pixel is divided into RED, GREEN, BLUE dots which are arranged in vertical stripe and this module can display 16.7 M colors.

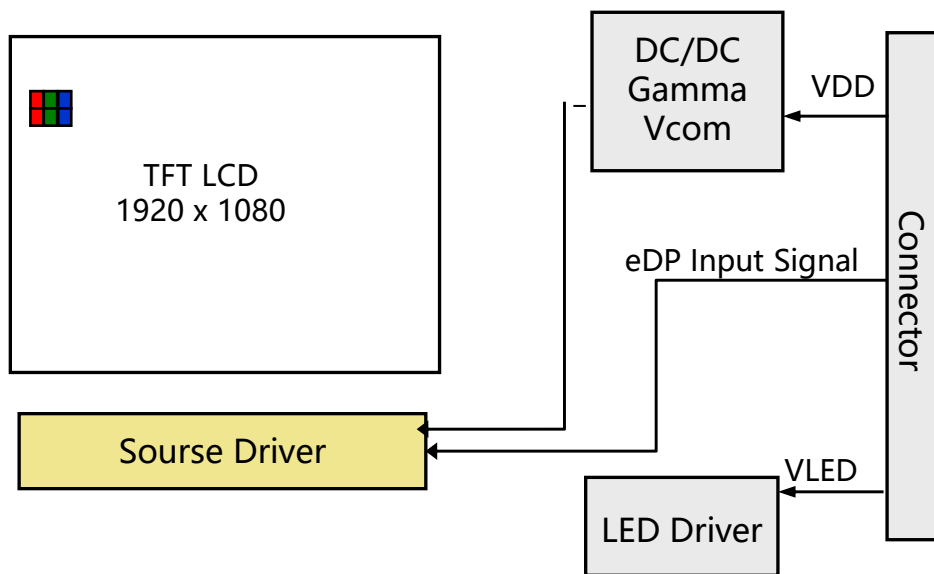

Figure 1. Drive Architecture

### 4.2 Features

- 2 lane eDP interface with 2.7Gbps link rates
- Thin and light weight
- 16.7M color depth, color gamut 72%

### 4.3 Application

- Video Phone/IP Phone/Smart Key/ e-cigarettes etc.

## 5. 0 ABSOLUTE MAXIMUM RATINGS

The followings are maximum values which, if exceed, may cause faulty operation or damage to the unit. The operational and non-operational maximum voltage and current values are listed in Table 2.

< Table 2. Environment Absolute Maximum Ratings> [Ta =25 ± 2 °C]

Parameter	Symbol	Min.	Max.	Unit	Remarks
Back-light Power Supply Voltage	HV <sub>DDOUT</sub>	-	-	V	Ta = 25 °C Note 1&2
Back-light LED Current	I <sub>HVDD</sub>	-	-	mA	
Back-light LED Reverse Voltage	V <sub>R</sub>	-	-	V	
Operating Temperature	T <sub>OP</sub>	-0	50	°C	Environment Temperature
Storage Temperature	T <sub>ST</sub>	-20	60	°C	
Operating Ambient Humidity	Hop	-	90	%RH	
Storage Humidity	Hst	-	90	%RH	
Heat Release Requirement	Trls	15		°C	

Note:

1. These range above is maximum value not the actual operating temperature . Actual Operating temperature is no more than 50°C and temperature refers to the LCM surface temperature ;
2. Leadtek is not responsible for product problems beyond the use conditions.
3. When the ambient temperature is T °C, the surface temperature of Panel can not exceed (T+15)°C.

## 5.1 TFT LCD Module

< Table3. LCD Module Electrical Specifications >

[Ta =25±2 °C]

Parameter	Symbol	Values			Unit	Notes
		Min	Typ	Max		
Power Supply Input Voltage	V <sub>DD</sub>	3.0	3.3	3.6	V	Note 1
Power Supply Current	I <sub>DD</sub>	-	-	-	mA	
LED Driver Power Supply Voltage	H <sub>VDD</sub>	-		-	V	
LED Driver Power Supply Current	I <sub>HVDD</sub>	-	-	-	mA	
LED Power Consumption	P <sub>LED</sub>	-	-	-	W	
Positive-going Input Threshold Voltage	V <sub>IT+</sub>	-		+100	mV	
Negative-going Input Threshold Voltage	V <sub>IT-</sub>	-100		-	mV	
Differential input common mode voltage	V <sub>com</sub>		TBD		V	

Notes : 1. The supply voltage is measured and specified at the interface connector of LCM.  
 The current draw and power consumption specified is for 3.3V at 25 °C  
 Max value at Black Pattern

2. Calculated value for reference  $I_{LED} \times V_{LED} \div 0.85 = P_{LED}$

## 5.2 Back-light Unit

< Table 4. LED Driving guideline specifications >

Ta=25+/-2°C

Parameter		Min.	Typ.	Max.	Unit	Remarks	
Power supply voltage for Back light		V <sub>LED</sub>	27	-	33	V	-
Power supply Current for Back light		I <sub>LED</sub>	-	180	-	mA	-
Power supply for Back light		P <sub>LED</sub>	4.8	-	5.94	W	-
LED Life-Time		N/A	-	-	30000	Hour	IF=36mA
EN Control Level	Backlight on	V <sub>ENH</sub>	-	-	-	V	EN logic high voltage
	Backlight off	V <sub>ENL</sub>	-	-	-	V	EN logic low voltage
PWM Control Level	PWM High Level	V <sub>PML</sub>	-	-	-	V	-
	PWM Low Level	V <sub>PML</sub>	-	-	-	V	-
PWM Control Frequency		F <sub>PWM</sub>	-	-	-	KHz	-
Duty Ratio		-	-	-	-	%	-

Notes : 1. Calculator Value for reference  $I_{LED} \times V_{LED} = P_{LED}$

2. The LED Life-time define as the estimated time to 50% degradation of initial luminous under the condition of the ambient temperature of 25°C.

## 6.0 INTERFACE CONNECTION.

### 6.1 Electrical Interface Connection

The electronics interface connector is IS050-L30B-C10.

The LED connector is MSK24022P10D

The connector interface pin assignments are listed in Table 5 and 6.

<Table 5. Pin Assignments for the Interface Connector>

PIN #	Symbol	Description Remark	PIN #	Symbol	Description Remark
1	CABC-EN	CABC-EN	16	GND	Power Ground
2	GND	Power Ground	17	HPD	Hot plug detect output
3	LANE1-N	eDP RX channel 1 negative	18	BL-GND	Power Ground
4	LANE1-P	eDP RX channel 1 positive	19	BL-GND	Power Ground
5	GND	Power Ground	20	BL-GND	Power Ground
6	LANE0-N	eDP RX channel 0 negative	21	BL-GND	Power Ground
7	LANE0-P	eDP RX channel 0 positive	22	BL-ENABLE	BL_PWM (NC)
8	GND	Power Ground	23	BL-PWM	BL_PWM (NC)
9	AUX-CH-P	eDP AUX CH positive	24	MSCL	FOR DEBUG
10	AUX-CH-N	eDP AUX CH negative	25	MSDA	FOR DEBUG
11	GND	Power Ground	26	BL-POWER	BL_POWER (NC)
12	LDC-VCC	3.3V	27	BL-POWER	BL_POWER (NC)
13	LCD-VCC	3.3V	28	BL-POWER	BL_POWER (NC)
14	LCD-TEST	Panel self test enable	29	BL-POWER	BL_POWER (NC)
15	GND	Power Ground	30	NC	NC

## 6.2 Data Input Format

Figure 2. Pixel Format

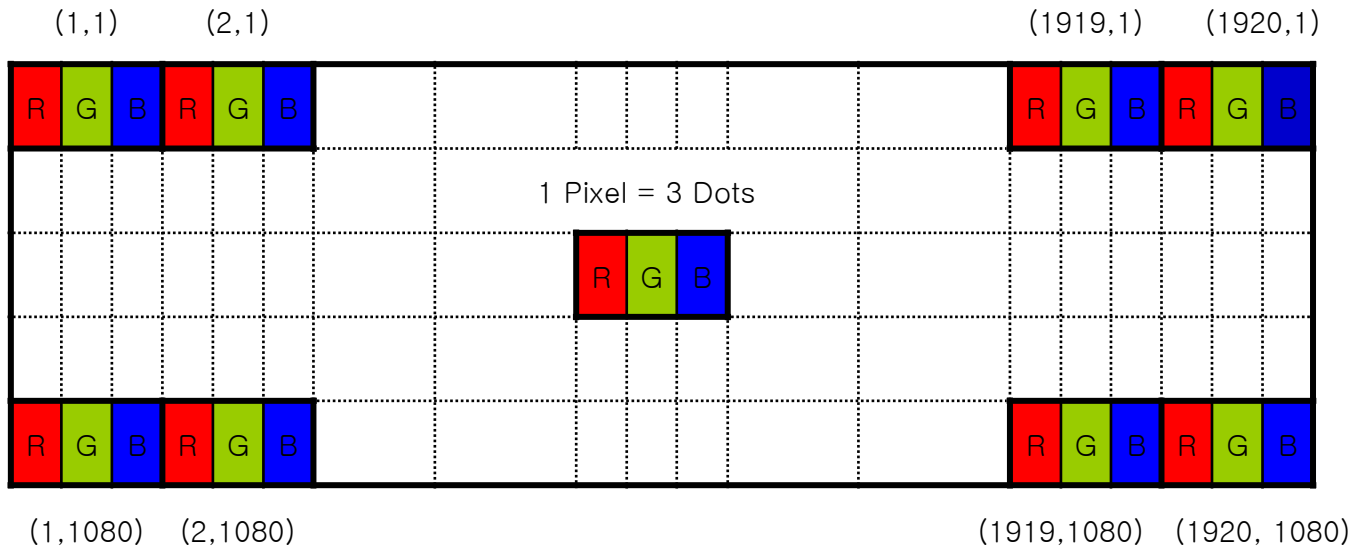

Display Position of Input Data (V-H)

Figure 3. Scan direction

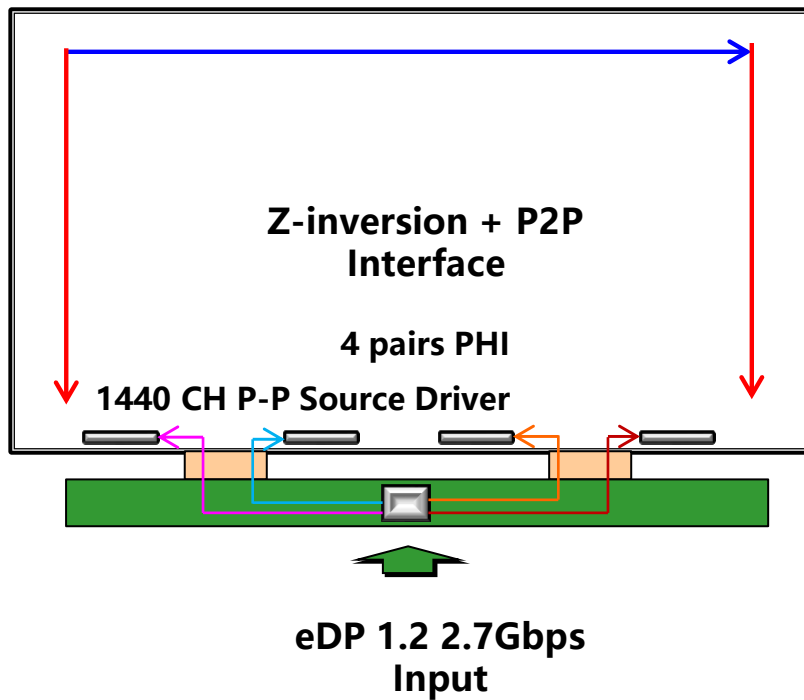

## 7.0 SIGNAL TIMING SPECIFICATION

### 7.1 The M133B50-116-9201 is operated by the DE only.

Item		Symbols	Min	Typ	Max	Unit
Clock	Frequency	1/Tc	100	147.8	160	MHz
	High Time	Tch	-	4/7Tc	-	Tc
	Low Time	Tcl	-	4/7Tc	-	Tc
Frame Period		Tv	1112	1125	1238	lines
			40	60	66	Hz
			25	16.67	15.15	ms
Vertical Display Period		Tvd	-	1080	-	lines
One line Scanning Period		Th	2080	2200	2400	clocks
Horizontal Display Period		Thd	-	1920	-	clocks

Note: The DCLK range at last line of V-blanking should be set in 0-H-active/2.

## 8.0 POWER SEQUENCE

To prevent a latch-up or DC operation of the LCD module, the power on/off sequence shall be as shown in below

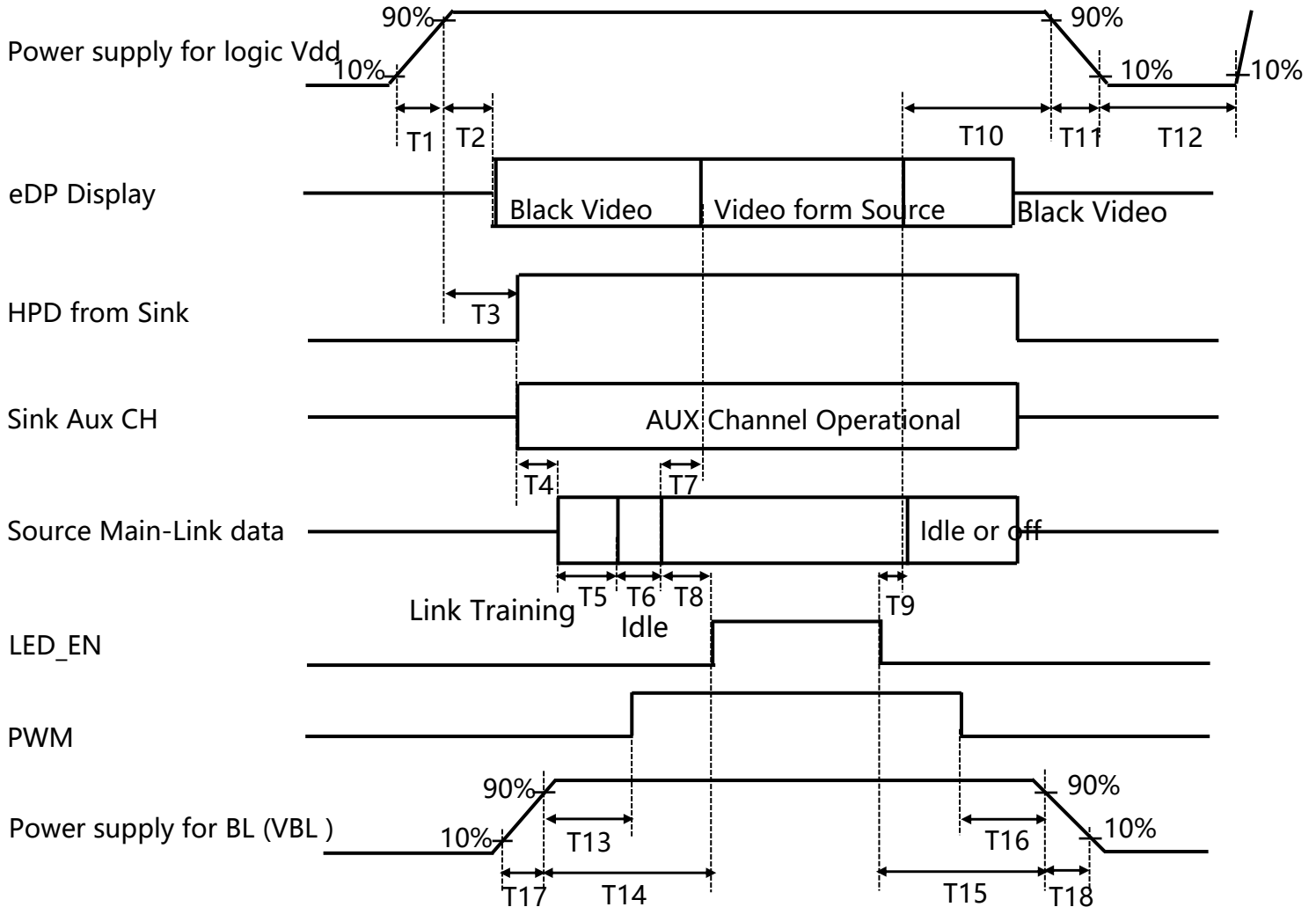

- $0.5\text{ms} \leq T1 \leq 10\text{ms}$
- $0\text{ms} \leq T2 \leq 200\text{ms}$
- $0\text{ms} \leq T3 \leq 200\text{ms}$
- $0\text{ms} \leq T13$
- $0\text{ms} \leq T14$
- $0\text{ms} \leq T17$
- $80\text{ms} \leq T8$
- $0\text{ms} \leq T7 \leq 50\text{ms}$
- $0\text{ms} \leq T10 \leq 500\text{ms}$
- $0.5\text{ms} \leq T11 \leq 10\text{ms}$
- $500\text{ms} \leq T12$
- $0\text{ms} \leq T15$
- $0\text{ms} \leq T16$
- $0\text{ms} \leq T18$

Notes:

1. When the power supply VDD is 0V, keep the level of input signals on the low or keep high impedance.
2. Do not keep the interface signal high impedance when power is on. Back Light must be turn on after power for logic and interface signal are valid.

## 9.0 OPTICAL SPECIFICATION

### 9.1 Overview

The test of view angle range shall be measured in a dark room (ambient luminance  $\leq 1$ lux and temperature =  $25 \pm 2^\circ\text{C}$ ) with the equipment of Luminance meter system (Goniometer system and TOPCON CS2000/CA310) and test unit shall be located at an approximate distance 50cm from the LCD surface at a viewing angle of  $\theta$  and  $\Phi$  equal to  $0^\circ$ . We refer to  $\theta \Phi = 0$  ( $= \theta 3$ ) as the 3 o'clock direction (the "right"),  $\theta \Phi = 90$  ( $= \theta 12$ ) as the 12 o'clock direction ("upward"),  $\theta \Phi = 180$  ( $= \theta 9$ ) as the 9 o'clock direction ("left") and  $\theta \Phi = 270$  ( $= \theta 6$ ) as the 6 o'clock direction ("bottom"). While scanning  $\theta$  and/or  $\Phi$ , the center of the measuring spot on the Display surface shall stay fixed. The luminance, color and uniformity (etc) should be tested by CS2000/CA310. The backlight should be operating for 10 minutes prior to measurement. VDD shall be  $3.3 \pm 0.3\text{V}$  at  $25^\circ\text{C}$ . Optimum viewing angle direction is 6 'clock

<Table 7. Optical Specifications>

Parameter		Symbol	Condition	Min.	Typ.	Max.	Unit	Remark
Viewing Angle range	Horizontal	$\Theta_3$	CR > 10	80	85	-	Deg.	Note 1
		$\Theta_9$		80	85	-	Deg.	
	Vertical	$\Theta_{12}$		80	85	-	Deg.	
		$\Theta_6$		80	85	-	Deg.	
Luminance Contrast ratio		CR	$\Theta = 0^\circ$	600	800	-		Note 2
Color Gamut	NTSC	CIE1931	$\Theta = 0^\circ$		72		%	Note 5
Reproduction of color	White	Wx	$\Theta = 0^\circ$					
		Wy						
Response Time		Tr+Td	Ta= $25^\circ\text{C}$ $\Theta = 0^\circ$	-	30	35	ms	Note 6

Notes : 1. Viewing angle is the angle at which the contrast ratio is greater than 10. The viewing angles are determined for the horizontal or 3, 9 o'clock direction and the vertical or 6, 12 o'clock direction with respect to the optical axis which is normal to the LCD surface (see FIGURE 1).

2. Contrast measurements shall be made at viewing angle of  $\Theta = 0$  and at the center of the LCD surface. Luminance shall be measured with all pixels in the view field set first to white, then to the dark (black) state. (see FIGURE 1) Luminance Contrast Ratio (CR) is defined mathematically.

$$CR = \frac{\text{Luminance when displaying a white raster}}{\text{Luminance when displaying a black raster}}$$

3. Luminance of white is defined as luminance values of center of the LCD surface. Luminance shall be measured with all pixels in the view field set first to white. This measurement shall be taken at the locations shown in FIGURE 2 for a total of the measurements per display. The luminance is measured by CS2000/CA310 when the LED current is set at 60mA.
4. The color chromaticity coordinates specified in Table 5. shall be calculated from the spectral data measured with all pixels first in red, green, blue and white. Measurements shall be made at the center of the panel.
5. The electro-optical response time measurements shall be made as FIGURE 3 by switching the "data" input signal ON and OFF. The times needed for the luminance to change from 10% to 90% is  $T_r$ , and 90% to 10% is  $T_d$ .

## 10.0 RELIABILITY TEST

The Reliability test items and its conditions are shown in below.

<Table 8. Reliability test>

No	Test Items	Conditions	Remark
1	High temperature storage test	Ta = 60° C , 60%RH, 48 hrs	
2	Low temperature storage test	Ta = -20° C , 48 hrs	
3	High temperature & high humidity operation test	Ta = 50° C , 90%RH, 48 hrs	
4	High temperature operation test	Ta = 50° C , 60%RH,48 hrs	
5	Low temperature operation test	Ta = -0° C , 48 hrs	
6	Thermal shock	Ta = -20° C ↔ 60° C (0.5 hr), 60% ± 3%RH, 10 cycle	
7	Vibration test (non-operating)	Ta = 25° C , 60%RH, 1.5G, 10~500Hz, Sine X,Y,Z / Sweep rate : 1 hour	Note 1
8	Shock test (non-operating)	Ta = 25° C , 60%RH, 220G, Half Sine Wave 2msec ± X, ± Y, ± Z Once for each direction	Note 1
9	Electro-static discharge test (operating)	Air : 150 pF, 330Ω, ± 15 KV Contact : 150 pF, 330Ω, ± 8 KV Ta = 25° C , 60%RH,	Note 2

Notes :

1. The fixture must be hard enough , so that the module would not be twisted or bent.
2. Self- recovery and restart recovery is allowed. No hardware failures.
- 3: Before cosmetic and function test, the product must have enough recovery timeat least 2 hours at room temperature.
- 4: in the standard condition, there shall be no practical problem that may affect thedisplay function. After the reliability test, the product only guarantees operation, but don'tguarantee all of the cosmetic specification.

## 11.0 Precautions

Please pay attention to the followings when you use this TFT LCD Panel.

### 1.1 Mounting Precautions

- (1) Use fingerstalls with soft gloves in order to keep display clean during the incoming inspection and assembly process.
- (2) You must mount a module using specified mounting holes (Details refer to the drawings).
- (3) Please make sure to avoid external forces applied to the Source PCB or FPC and D-IC during the process of handling or assembling. If not, It causes panel damage or malfunction.
- (4) Note that polarizers are very fragile and could be easily damaged. Do not touch, push or rub the exposed polarizers with glass, tweezers or anything harder than HB pencil lead. And please do not rub with dust clothes with chemical treatment.
- (5) Do not pull or fold the source D-IC which connect the source PCB or FPC and the panel.
- Do not pull or fold the LED wire.
- (6) After removing the protective film, when the surface becomes dusty, please wipe gently with absorbent cotton or other soft materials like chamois soaks with alcohol or purified water.
- Do not strong polar solvent because they cause chemical damage to the polarizer.
- (7) Wipe off saliva or water drops as soon as possible. Their long time contact with polarizer causes deformations and color fading.
- (8) Protection film for polarizer on the module shall be slowly peeled off just before use so that the electrostatic charge can be minimized.
- (9) Since the LCD is made of glass, do not apply strong mechanical impact or static load onto it. Handling with care since shock, vibration, and careless handling may seriously affect the product. If it falls from a high place or receives a strong shock, the glass may be broken.
- (10) Do not disassemble the module.
- (11) To determine the optimum mounting angle, refer to the viewing angle range in the specification for each model.
- (12) If the customer's set presses the main parts of the LCD, the LCD may show the abnormal display. But this phenomenon does not mean the malfunction of the LCD and should be pressed by the way of mutual agreement.
- (13) Do not drop water or any chemicals onto the LCD's surface.

## 11.1 Operating Precautions

- (1) Be careful for condensation at sudden temperature change. Condensation makes damage to polarizer or electrical contacted parts. And after fading condensation, smear or spot will occur.
- (2) Module has high frequency circuits. Sufficient suppression to the electromagnetic interference shall be done by system manufacturers. Grounding and shielding methods may be important to minimized the interference.
- (3) The electrochemical reaction caused by DC voltage will lead to LCD degradation, so DC drive should be avoided.
- (4) The LCD modules use C-MOS LSI drivers, so customers are recommended that any unused input terminal would be connected to Vdd or Vss, do not input any signals before power is turn on, and ground you body, work/assembly area, assembly equipments to protect against static electricity.
- (5) Do not exceed the absolute maximum rating value. (supply voltage variation, input voltage variation, variation in part contents and environmental temperature, and so on) Otherwise the Module may be damaged.
- (6) Design the length of cable to connect between the connector for back-light and the converter as short as possible and the shorter cable shall be connected directly.

The longer cable between that of back-light and that of converter may cause the luminance of LED to lower and need a higher startup voltage(Vs).

- (7) Connectors are precise devices for connecting PCB and transmitting electrical signals. Operators should insert and unplug MDL in parallel when assembling MDL.
- (8) Do not connect or disconnect the cable to/ from the module at the "Power On" condition.
- (9) When the module is operating, do not lose CLK, ENAB signals. If any one these signals is lost, the LCD panel would be damaged.
- (10) Obey the supply voltage sequence. If wrong sequence is applied, the module would be damaged.
- (11) Do not re-

## 11.2 Electrostatic Discharge Control

- (1) Since a module is composed of electronic circuits, it is not strong to electrostatic discharge. Make certain that treatment persons are connected to ground through wrist band etc. And don't touch interface pin directly. Keep products as far away from static electricity as possible.
- (2) Avoid the use work clothing made of synthetic fibers. We recommend cotton clothing or other conductivity-treated fibers.

### 11.3 Precautions for Strong Light Exposure

It is not allowed to store or Operate directly in strong light or in high temperature and humidity for a

### 11.4 Storage Precautions

When storing modules as spares for a long time, the following precautions are necessary.

- (1) Control of ventilation and temperature is necessary.
- (2) Please make sure to protect the product from strong light exposure, water or moisture.  
Be careful for condensation.
- (3) Store in a polyethylene bag with sealed so as not to enter fresh air outside in it.
- (4) Do not store the LCD near organic solvents or corrosive gasses.
- (5) Please keep the FOB at a circumstance shown below Fig.

### 11.5 Precautions for Protection Film

- (1) Remove the protective film slowly, keeping the removing direction approximate 30-degree not vertical from panel surface, If possible, under ESD control device like ion blower, and the humidity of working room should be kept over 50%RH to reduce the risk of static charge.
- (2) In handling the LCD, wear non-charged material gloves. And the conducting wrist to the earth and

### 11.6 Appropriate Condition for Display

- (1) Normal operating condition
  - Temperature: 0 ~ 40°C
  - Operating Ambient Humidity : 10 ~ 90 %
  - Display pattern: dynamic pattern (Real display)
  - Long-term lighting products recommended regular shutdown

- (2) Special operating condition

If the product will be used in extreme conditions such as high temperature, humidity, display patterns or 7\*24hrs operation time etc..., It is strongly recommended to contact Leadtek for Application engineering advice. Otherwise, its reliability and function may not be guaranteed.

- (3) Black image or moving image is strongly recommended as a screen save.

- (4) Lifetime in this spec. is guaranteed only when commercial display is used according to operating usages.
- (5) Please contact Leadtek in advance when you want to switch between portrait and landscape screen
- (6) Please contact Leadtek in advance for outdoor operation.
- (7) Please contact Leadtek in advance when you display the same pattern for a long time.
- (8) If the Module keeps displaying the same pattern for a long period of time, the image may be "sticked" to the screen. To avoid image sticking, it is recommended to use a screen saver.
- (9) Do not exceed the absolute maximum rating value. (supply voltage variation, input voltage variation, variation in part contents and environmental temperature, and so on) Otherwise the Module be damaged.
- (10) Dew drop atmosphere should be avoided.
- (11) The storage room should be equipped with a good ventilation facility and avoid to expose to corrosive gas , which has a temperature controlling system.
- (12) When expose to drastic fluctuation of temperature (hot to cold or cold to hot) ,the LCD may be affected; Specifically, drastic temperature fluctuation from cold to hot ,produces dew on the LCD's surface which may affect the operation of the polarizer and the LCD.
- (13) Response time will be extremely delayed at lower temperature than the operating temperature range and on the other hand at higher temperature LCD may turn black at temperature above its operational range. However those phenomena do not mean malfunction or out of order with the LCD. The LCD will revert to normal operation once the temperature returns to the recommended temperature range for normal operation

## 11.7 Others

### A. LC Leak

- If the liquid crystal material leaks from the panel, it is recommended to wash the LC with acetone or ethanol and then burn it.
- In case of contact with hands, skin or clothes, it has to be washed away thoroughly with soap.
- If LC in mouth, mouth need to be washed, drink plenty of water to induce vomiting and follow medical advice.
- If LC touch eyes, eyes need to be washed with running water at least 15 minutes.

### B. Rework

- When returning the module for repair or etc., Please pack the module not to be broken. We recommend to use the original shipping packages.

## 12. Packing form-TBD



# 深圳市丽台电子有限公司

Shenzhen Leadtek Electronics Co.,Ltd

# Incoming Inspection Standard

## 品质允收标准

Model N0. /产品型号: Applicable to Leadtek Touch Display Screen

Updated Date /生效日期: 2025.04.01

Version / 版本号: V0

Record of Revision /修订履历.

Version /版本号	Revision Record /修订内容	Reviser /修订人	Revision Date /修订日期
V0	首发 / Initial release	Green	2025.04.01



## 1、Scope of application /适用范围.

适用于丽台电子触摸显示屏/ Applicable to Leadtek Touch Display Screen.

## 2、Inspection conditions and environment / 检验条件与环境.

### 2.1、Inspection Conditions / 检验条件:

2.1.1、Inspection Distance / 检测距离: 35cm ±5cm.

2.1.2、Inspection time /检验时间: Displays performance test /功能测试: 2~3S /Image, Appearance Inspection / 外观检验: 8~10S.

2.1.3、Inspection the viewing angle /检验视角:

Display Inspection Angle /显示检验角度: ±45°.

Appearance Inspection Angle /外观检验角度: ±45°.

Eye position /眼睛位置:

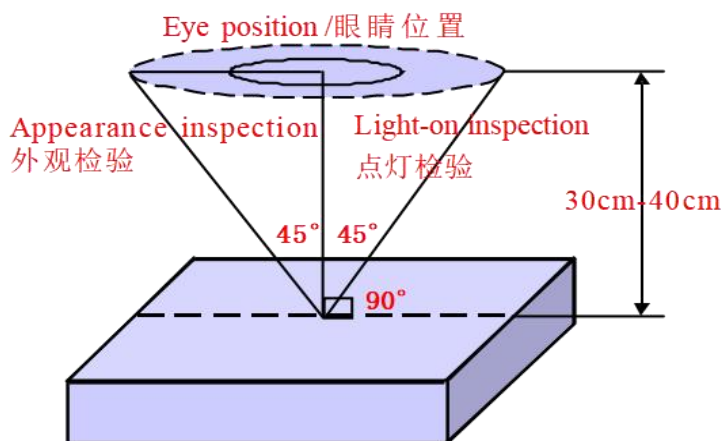

(Perpendicular to LCD panel surface /垂直于LCD表面)

### 2.2、Inspection environment /检验环境:

Temperature / 温度		25±5°C
Humidity / 湿度		55±5%RH
Brightness 亮度	Appearance Inspection / 外观检验	800~1000 Lux
	Display Inspection / 功能检验	200~300 Lux

## 2.3、Sampling conditions / 抽样方式.

Sampling Plan / 抽样计划		GB/T 2828.1- 2003
		Batch single sampling/批量单次抽样
		General inspection level: II/一般检验水平: 二级
AQL	Major Defect / 主要缺陷	0.25
	Minor Defect / 次要缺陷	0.65

## 3、Terms and definitions / 术语和定义.

### 3.1、Defect classification / 缺陷分类:

3.1.1、Major defects / 主要缺陷: Defects that cause the product to fail or reduce the usability of the product / 引起产品功能失效和减少产品的有效使用与操作的缺陷.

3.1.2、Minor defects / 次要缺陷: Defects that do not affect the functionality and effective use and operation of the product / 不影响产品功能和有效使用与操作的缺陷.

### 3.2、Point defects / 点状缺陷:

The size of a punctate defect is defined by the diameter  $D$ , and the average diameter of the defect is  $D=1/2(W+L)$  / 点状缺陷由直径  $D$  定义大小, 缺陷的平均直径  $D=1/2(W+L)$ .

### 3.3、line defects / 线状缺陷:

When defect size  $L \geq 2W$ , the defect count as liner type defect. Size of linear defect is defined by length ( $L$ ) and the maximum width ( $W$ )

当缺陷尺寸  $L \geq 2W$  时, 被视为线状缺陷, 线状缺陷是由长度 ( $L$ ) 和最大宽度 ( $W$ ) 定义的.

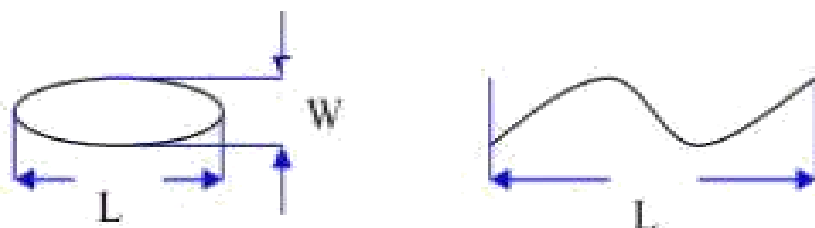

### 3.4、LCD sub-pixels / LCD 子像素点:

The sub-pixel defect area is greater than 50% of the LCD sub-pixel area, and is visible through ND5% masking

子像素点缺陷面积大于 50% LCD 子像素面积, 且透过 ND5%遮盖是可见的.

### 3.5、ND card test method / ND 卡检验方法:

Hold the ND card about 5cm above the display area, with your eyes 30-40cm away from the panel, and observe for 2~3 seconds

在显示区域上方大约 5cm 处握住 ND 卡, 眼睛距离面板 30-40cm, 观察 2~3 秒.

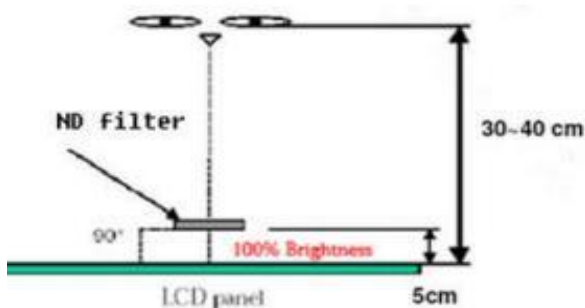

3.6、Surface substances that can be cleaned are not considered defects (e.g. finger prints on the protective film, dust particles)

可以被清洁干净的表面物质不视为缺陷 (如保护膜上的手指印, 尘粒) .

3.7、Defects that can be covered by the material and are not visible to the eye, and do not affect the function and use are not considered defects

能被物料覆盖目视不可见, 且不影响功能与使用的缺陷不视为缺陷.

3.8、AA shows that damage to the glass outside the area does not affect the effective line and does not expand the loss is acceptable

AA 显示区域以外的玻璃损伤, 不影响有效线路和不会在扩大损失的是可以接受的.

3.9、Issues not specified or defined in this document shall be dealt with through friendly negotiation between the parties / 本文件中未规定或定义的问题, 双方友好协商处理.

## 4.0、Inspection standards /检验标准:

### 4.1、Structural size standards / 结构尺寸标准:

Measurement items /测量项目		Specification /规格	Remark /备注
Name/名称	Unit /单位	Tolerance /公差	
Outside dimension: Length 尺寸: 长	mm /毫米	0.10mm~0.3mm	Please refer to the product specification for detailed dimensions and tolerances 详细的尺寸规格和公差请参考产品规格书
Outside dimension: Width 尺寸: 宽	mm /毫米	0.10mm~0.3mm	
Outside dimension: Thickness 尺寸: 厚	mm /毫米	0.20mm~0.50mm	

### 4.2、Appearance Inspection standards:

( D : diameter, W : width, L : length, N : quantity, DS : spacing )

Material 检验区域	Inspection items 检验项目	Product size 适用尺寸	Inspection standards 检验规格	Category 缺陷类别	
LCD	ITO	Full size 全尺寸	ITO can't open circuit, short circuit, ITO notch cannot exceed 70% of width. ITO 不能有开路 and 短路, ITO 缺口不能超过宽度的70%.	MA	
	Corners broken 崩边/崩角	Full size 全尺寸	1、 It cannot affect the appearance of valid routes and functions; 不能影响有效线路和功能外观.	MA	
			2、 There must be no extensible rips 不能有可延伸性裂纹.	MA	
Silicone 硅胶	Silicone coating 硅胶涂布	Full size 全尺寸	1、 The height cannot exceed the LCD CF surface / 高度不能超过 LCD CF 面.		MI
			2、 No overflow and lack of glue / 不能溢胶和缺胶.		MI
			3、 Silicone cannot cover POL and FPC/ 硅胶不能覆盖到 POL 和 FPC.		MI

Material 检验区域	Inspection items 检验项目	Product size 适用尺寸	Inspection standards 检验规格	Category 缺陷类别	
PCBA FPC Connector 连接器	Appearance 表面外观	Full size 全尺寸	1.FPC is not allowed to have drape/bubble/fold / 不允许有披锋/气泡/褶皱.		MI
			2.Surface scratches do not allow copper leakage / 表面划伤不允许出现漏铜.	MA	
			3.Cracking is not allowed / 不允许破裂.	MA	
			4.Gold finger oxidation is not allowed 不允许金手指氧化.	MA	
			5.Chromatic aberration is not allowed 不允许出现色差.	MA	
	Components 元器件	Full size 全尺寸	1. Damage, missing parts, and incorrect models are not allowed 不允许损伤、缺件、型号错误.	MA	
			2.Components need to be insulated with high temperature adhesive (unless not required by the drawings) / 元器件需要有高温胶绝缘保护 (除非图纸无要求) .		MI
			3.The pads need to be glued with high temperature (unless not required by the drawings) / 焊盘需贴高温胶 (除非图纸无要求) .		MI
	Weld 焊接	Full size 全尺寸	1. False soldering, virtual soldering, and tinning are not allowed 不允许假焊、虚焊、连锡.	MA	
			2. No solder bead residue is allowed 不允许有锡珠残留.		MI
3.The pads need to be glued with high temperature (unless not required by the drawings) / 焊盘需贴高温胶 (除非图纸无要求) .				MI	
POL 偏光片	Scratches 划伤	Under 6 inches 6寸以下	1.W≤0.05mm; L≤5mm, Ignore (忽略) . 2.0.05mm < W≤0.10mm ; L≤5mm ; N≤2; DS≥10mm. 3.0.10mm < W; 5mm < L, Not allowable (不允许) .		MI
		6~10.0 inches 6寸~10.0寸	1.W≤0.07mm; L≤5mm, Ignore (忽略) . 2.0.07mm < W≤0.12mm ; L≤10mm ; N≤3 ; DS≥10mm. 3.0.12mm < W; 10mm < L, Not allowable (不允许) .		MI
		More than 10 inches 10寸以上	1.W≤0.10mm; L≤5mm, Ignore (忽略) . 2.0.10mm < W≤0.15mm ; L≤10mm ; N≤4 ; DS≥10mm. 3.0.15mm < W; 10mm < L, Not allowable (不允许) .		MI

Material 检验区域	Inspection items 检验项目	Product size 适用尺寸	Inspection standards 检验规格	Category 缺陷类别	
POL 偏光片	Bubbles	Under 6 inches 6寸以下	1.D≤0.15mm, Ignore (忽略) . 2.0.15mm < D≤0.30mm; N≤2; DS≥10mm. 3.D > 0.30mm, Not allowable (不允许) .		MI
		More than 6 inches 6寸以上	1.D≤0.20mm, Ignore (忽略) . 2.0.20mm < D≤0.40mm; N≤3; DS≥10mm. 3.D > 0.40mm, Not allowable (不允许) .		MI
	Bubbles around the edges 边缘气泡	Full size 全尺寸	1.Within 1/2BM of the display area, it is not allowed 显示区往外 1/2BM 区域内, 不允许. 2.The display area is 1/2 outside the BM area, and it is not controlled 显示区往外 1/2BM 区域以外, 不管控.		MI
	Point defects Embossing	Under 6 inches 6寸以下	1.D≤0.15mm, Ignore (忽略) . 2.0.15mm < D≤0.30mm; N≤2; DS≥10mm. 3.D > 0.30mm, Not allowable (不允许) .		MI
		6~10.0 inches 6寸~10.0寸	1.D≤0.20mm, Ignore (忽略) . 2.0.20mm < D≤0.40mm; N≤3; DS≥10mm. 3.D > 0.40mm, Not allowable (不允许) .		MI
		More than 10 inches 10寸以上	1.D≤0.25mm, Ignore (忽略) . 2.0.25mm < D≤0.50mm; N≤4; DS≥10mm. 3.D > 0.50mm, Not allowable (不允许) .		MI
	Dirty 脏污	Full size 全尺寸	Dirt, finger prints, etc. are not allowed 不允许有脏污、手指印等.		MI
	Warping 起翘	Full size 全尺寸	Not allowed 不允许.		MI
	Paste offset 贴附偏位	Full size 全尺寸	It is not allowed to exceed the patch tolerance required by the drawing; After TP lamination, it is not allowed to leak the edges of the polarizer 不允许超出图纸要求的贴片公差; 在 TP 贴合后不允许漏偏光片边缘.		MI
	Angle mistake 角度错误	Full size 全尺寸	Not allowed 不允许.		MA
Mixture 混料	Full size 全尺寸	Not allowed 不允许.		MA	

Material 检验区域	Inspection items 检验项目	Product size 适用尺寸	Inspection standards 检验规格	Category 缺陷类别		
TP	Scratches 划伤	Under 6 inches 6寸以下	1.W≤0.05mm; L≤5mm, Ignore (忽略) . 2.0.05mm < W≤0.10mm ; L≤5mm ; N≤2 ; DS≥10mm. 3.0.10mm < W; 5mm < L, Not allowable (不允许) . 4.There is a feeling scratch, Not allowable 有感划伤, 不允许.		MI	
		6~10.0 inches 6寸~10.0寸	1.W≤0.07mm; L≤5mm, Ignore (忽略) . 2.0.07mm < W≤0.12mm ; L≤10mm ; N≤3 ; DS≥10mm. 3.0.12mm < W; 10mm < L, Not allowable (不允许) . 4.There is a feeling scratch, Not allowable 有感划伤, 不允许.		MI	
		More than 10 inches 10寸以上	1.W≤0.10mm; L≤5mm, Ignore (忽略) . 2.0.10mm < W≤0.15mm ; L≤10mm ; N≤4 ; DS≥10mm. 3.0.15mm < W; 10mm < L, Not allowable (不允许) . 4.There is a feeling scratch, Not allowable 有感划伤, 不允许.		MI	
	Black dots white dots 黑点/白点	Under 6 inches 6寸以下	1.D≤0.15mm, Ignore (忽略) . 2.0.15mm < D≤0.30mm; N≤2; DS≥10mm. 3.D > 0.30mm, Not allowable (不允许) .			MI
		6~10.0 inches 6寸~10.0寸	1.D≤0.20mm, Ignore (忽略) . 2.0.20mm < D≤0.40mm; N≤3; DS≥10mm. 3.D > 0.40mm, Not allowable (不允许) .			MI
		More than 10 inches 10寸以上	1.D≤0.25mm, Ignore (忽略) . 2.0.25mm < D≤0.50mm; N≤4; DS≥10mm. 3.D > 0.50mm, Not allowable (不允许) .			MI
	OCA Bubbles 气泡	Full size 全尺寸	Not allowed 不允许.			MI
	Corners broken 崩边/崩角	Full size 全尺寸	1.Product front /产品正面: Edge and corner chipping is not allowed / 崩角、崩边不允许 2.Product back /产品背面: X≤0.5, Y≤0.5, Z≤1/2T; N≤4; DS≥10mm.		MA	
	Silk screen 丝印	Full size 全尺寸	The silk screen is clear, complete and correct 丝印清晰、完整、内容正确.			MI

Material 检验区域	Inspection items 检验项目	Product size 适用尺寸	Inspection standards 检验规格	Category 缺陷类别
TP	Dirty 脏污	Full size 全尺寸	Uncleanable dirt, Not allowable. 不可擦拭的脏污, 不允许.	MI
	Broken 破损	Full size 全尺寸	Not allowable. 不允许.	MI
	Ink color aberration 油墨色差	Full size 全尺寸	$\Delta E > 1$ , Not allowable (不允许).	MI
	Cover pinholes 针孔	Full size 全尺寸	1.D $\leq$ 0.20mm, N $\leq$ 2, DS $\geq$ 10mm, allowable 2.D > 0.20mm, intensive pinholes (密集型针孔), Not allowable (不允许).	MI
	Paint off 掉漆	Full size 全尺寸	Touch-up on the back of the cover is allowed, and the touch-up area cannot exceed 2.0mm in diameter / 允许在盖板背面补漆, 补漆面积不 能超过直径 2.0mm.	MI
BL 背光	Backlight separation 背光分离	Full size 全尺寸	Not allowable 不允许.	MI
	Deformed 变形	Full size 全尺寸	Measured using a plug gauge, If the deformation exceeds 0.3mm, NG is judged 使用塞规测量, 形变超过 0.3mm, 判定 NG.	MI
	Iron frame Oxidation /abscission 铁框氧化/脱落	Full size 全尺寸	Not allowable 不允许.	MI
	Dirt/adhesive residue/solder beads 脏污/残胶/锡珠	Full size 全尺寸	Not allowable 不允许.	MI
	Inkjet/barcode/ QR code 喷码/条码/二维 码	Full size 全尺寸	The inkjet code is clear and complete, the barcode and QR code can be scanned normally, and the content and format meet the requirement / 喷码清晰完整、条码和二维码 可正常扫描, 内容和格式与要求相符.	MI
	Auxiliary materials 辅料	Full size 全尺寸	Accessories (vinyl, double-sided tape, insulating glue, etc.) are not allowed to be missed, misguided, defective, etc 辅料(黑胶、双面胶、绝缘胶等)不允许有漏贴、 贴偏、残缺等.	MI

### 4.3、Functional inspection standards:

( D : diameter, W : width, L : length, N : quantity, DS : spacing )

Material 检验区域	Inspection items 检验项目	Product size 适用尺寸	Inspection standards 检验规格	Category 缺陷类别	
Display Screen 模组	Light leakage / Mura 漏光/ Mura	Full size 全尺寸	1.Use ND5% filter masking, visual invisibility is OK 使用 ND5%遮盖, 目视不可见即为 OK. 2.If necessary, sign off on the sample 必要时, 签限定样.		MI
	Brightness uniformity 亮度均匀性	Full size 全尺寸	Brightness uniformity < 85.0%, Not allowable 亮度均匀性 < 85.0%, 不允许.	MA	
	LCD bright spots/dark spots 玻璃亮点/暗点	Under 6 inches 6寸以下	1.D≤0.10mm, Ignore (忽略) . 2.0.10mm < D≤0.20mm; N≤2; DS≥10mm. 3.D > 0.20mm, Not allowable (不允许) .		MI
		6~10.0 inches 6寸~10.0寸	1.D≤0.15mm, Ignore (忽略) . 2.0.15mm < D≤0.30mm; N≤3; DS≥10mm. 3.D > 0.30mm, Not allowable (不允许) .		MI
		More than 10 inches 10寸以上	1.D≤0.20mm, Ignore (忽略) . 2.0.20mm < D≤0.40mm; N≤4; DS≥10mm. 3.D > 0.40mm, Not allowable (不允许) .		MI
	Backlight black dots/white dots 背光黑点/白点	Under 6 inches 6寸以下	1.D≤0.15mm, Ignore (忽略) . 2.0.15mm < D≤0.30mm; N≤2; DS≥10mm. 3.D > 0.30mm, Not allowable (不允许) .		MI
		6~10.0 inches 6寸~10.0寸	1.D≤0.20mm, Ignore (忽略) . 2.0.20mm < D≤0.40mm; N≤3; DS≥10mm. 3.D > 0.40mm, Not allowable (不允许) .		MI
		More than 10 inches 10寸以上	1.D≤0.25mm, Ignore (忽略) . 2.0.25mm < D≤0.50mm; N≤4; DS≥10mm. 3.D > 0.50mm, Not allowable (不允许) .		MI
	Linear foreign bodies 线状异物	Under 6 inches 6寸以下	1.W≤0.05mm; L≤5mm, Ignore (忽略) . 2.0.05mm < W≤0.10mm ; L≤5mm ; N≤2; DS≥10mm. 3.0.10mm < W; 5mm < L, Not allowable (不允许) .		MI
		6~10.0 inches 6寸~10.0寸	1.W≤0.07mm; L≤5mm, Ignore (忽略) . 2.0.07mm < W≤0.12mm ; L≤10mm ; N≤3 ; DS≥10mm. 3.0.12mm < W; 10mm < L, Not allowable (不允许) .		MI
		More than 10 inches 10寸以上	1.W≤0.10mm; L≤5mm, Ignore (忽略) . 2.0.10mm < W≤0.15mm ; L≤10mm ; N≤4 ; DS≥10mm. 3.0.15mm < W; 10mm < L, Not allowable (不允许) .		MI

Material 检验区域	Inspection items 检验项目	Product size 适用尺寸	Inspection standards 检验规格	Category 缺陷类别	
Display Screen 模组	White/Black print 白印/黑印	Full size 全尺寸	Use ND5% filter masking, visual invisibility is OK 使用 ND5%遮盖, 目视不可见即为 OK.		MI
	Interference pattern/Newtonian pattern 干涉纹/牛顿纹	Full size 全尺寸	Not allowable 不允许.		MI
	Membranes displacement 膜材移位	Full size 全尺寸	Not allowable 不允许.		MI
	Color blocks 色斑	Full size 全尺寸	Use ND5% filter masking, visual invisibility is OK /使用 ND5%遮盖, 目视不可见即为 OK.		MI
	Display abnormal 画异	Full size 全尺寸	Not allowable 不允许.	MA	
	No display 无显示	Full size 全尺寸	Not allowable 不允许.	MA	
	Line/Missing Drawing 线条/缺画	Full size 全尺寸	Not allowable 不允许.	MA	
	Splash screen 闪屏	Full size 全尺寸	Not allowable 不允许.	MA	
	LCD grid LCD 网格	Full size 全尺寸	Not allowable 不允许.	MA	
	Afterimage 残影	Full size 全尺寸	Not allowable 不允许.	MA	
	Wrong viewing angle 可视角错误	Full size 全尺寸	Not allowable 不允许.	MA	
TP	No touch 无触摸	Full size 全尺寸	Not allowable 不允许.	MA	
	Touch the jump point 触摸跳点	Full size 全尺寸	Not allowable 不允许.	MA	
	Touch not sensitive 触摸不灵敏	Full size 全尺寸	Not allowable 不允许.	MA	