

# Shenzhen Leadtek Electronics Co.,Ltd

## PRODUCT SPECIFICATION

### TFT-LCD MODULE

**Module No: LTK080FTBCT25-V0**

Preliminary Specification

Approval Specification

Designed by	Checked by	Approved by
<i>jona</i>	<i>Jerry</i>	<i>lan</i>

### Final Approval by Customer

Approved by	Comment

※The specification of "TBD" should refer to the measured value of sample . If there is difference between the design specification and measured value, we naturally shall negotiate and agree to solution with customer.



## 2.GENERAL INFORMATION

N0	Item	Specification	Unit	Remark
1	LCD Size	TFT"8.0	inch	-
2	Panel Type	IPS	-	-
3	Display Resolution	1200 RGB (H) x1920 (V)	pixel	-
4	Display mode	Normally Black	-	-
5	Display colors	16.7M	-	-
6	Viewing Direction	ALL	-	-
7	CTP+LCM Module Size	132.60 (W) x193.60(V) x4.37(T)	mm	Note
8	Active Area	107.64(H) x 172.22 (V)	mm	Note
9	Pixel Pitch	0.0897(W) x0.0897(V)	mm	-
10	Weight	TBD	g	-
11	Driver IC	-	bit	-
12	Light Source	24 White LED	-	-
13	Interface	MIPI	-	-

8.0 (10:16 diagonal) inch configuration

## 3.Mechanical Drawing

# Front View

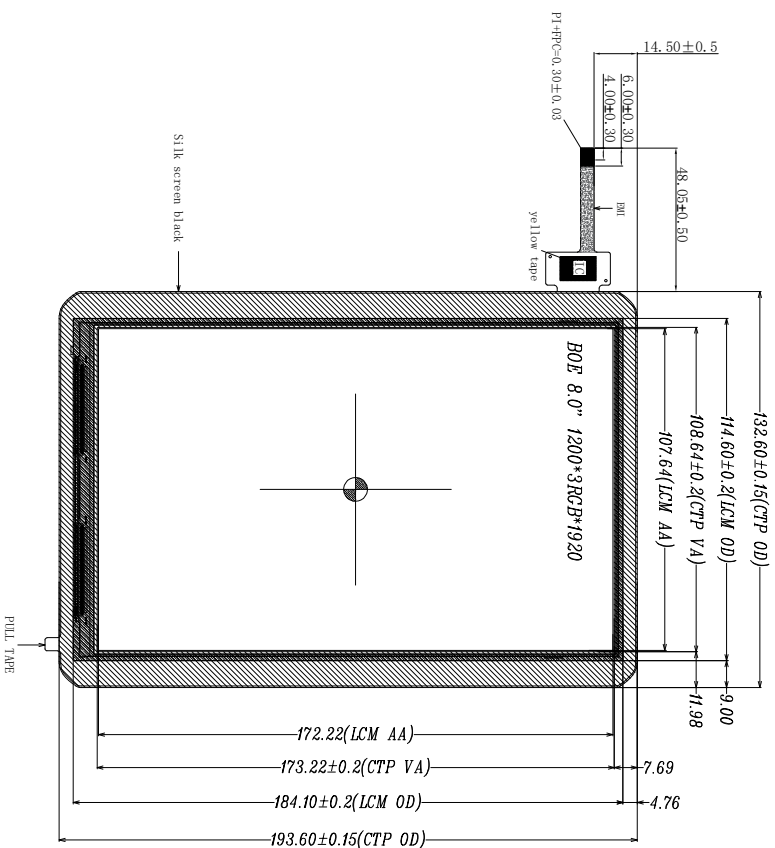

# Side View

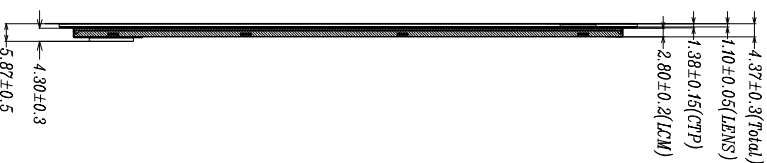

# Back View

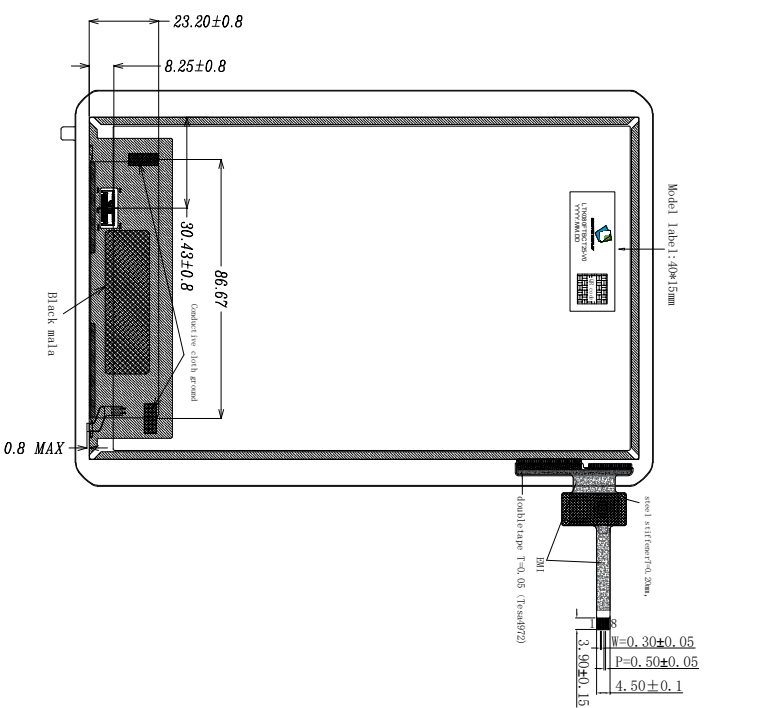

PIN	DESCRIPTION
1	LED+
2	LED+
3	LED+
4	NC
5	NC
6	LED+
7	LED+
8	LED+
9	GND
10	GND
11	MP1 D2+
12	MP1 D2-
13	GND
14	MP1 D1+
15	MP1 D1-
16	GND
17	MP1 CLK
18	MP1 CLK
19	GND
20	MP1 D0+
21	MP1 D0-
22	GND
23	MP1 D3+
24	MP1 D3-
25	GND
26	GND
27	RES1 / NC
28	TP
29	NC
30	VDDV3
31	VDDV3

PIN	SYMBOL
1	V10 (1.8V)
2	VDD2 (5.0V)
3	RESER (1.8V)
4	INT (1.8V)
5	SMA (1.8V)
6	SCL (1.8V)
7	GND
8	GND

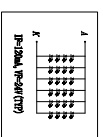

- CTP NOTE:**
1. Structure: G+P+P.
  2. Transmittance:  $\geq 83\%$  (550nm).
  3. All unmarked tolerances:  $\pm 0.10$ mm.
  4. IC: G19271, 10-point touch.
  5. Degree of toughness: 110g steel ball, height 40cm drop without breaking, surface hardness.
  6. The key hole and edge of the unmarked place in the G+ are safely chamfered  $\leq 0.20$ mm.
  7. Working temperature:  $-10^{\circ}\text{C} \sim 50^{\circ}\text{C}$ ,  $20^{\circ}\text{C}$  85%RH, storage temperature  $-20^{\circ}\text{C} \sim 60^{\circ}\text{C}$ , 10-95%RH.
- All materials comply with ROHS.

- Notes:**
1. Display : 8.0", TFT
  2. Resolution: 1200xRGBx1920
  3. LCD Viewing Direction: all
  4. Display Mode: Normally Black
  5. LCM+CTP Brightness: 510cd/m<sup>2</sup>(TYP)
  6. unmark Tolerance:  $\pm 0.2$
  7. OPERATING TEMP:  $-10^{\circ}\text{C} \sim 50^{\circ}\text{C}$
  8. STORAGE TEMP:  $-20^{\circ}\text{C} \sim 60^{\circ}\text{C}$
  9. Requirements on Environmental Protection: ROHS

REV	DESCRIPTION	DATE	NAME
3			
2			
1	NEW	2025.04.07	Kevin

  
**Shenzhen Leadtek Electronics Co., Ltd**

SCALE: 1/1	UNIT: mm	PAGE: 1/1	APPROVE	CHECK	DRAWN
PART NO:	LTK080FTBCT25	VER: V0	Ian	Jona	Kevin
CUSTOMER NO:					

## 4.0 Interface Pin Connection

### 4.1 TFT LCD Module

PIN NO	SYMBOL	DESCRIPTION
1	LEDA	Power for LED backlight (Anode)
2	LEDA	Power for LED backlight (Anode)
3	LEDA	Power for LED backlight (Anode)
4	NC	No connect.
5	NC	No connect.
6	LEDK	Power for LED backlight (Cathode)
7	LEDK	Power for LED backlight (Cathode)
8	LEDK	Power for LED backlight (Cathode)
9	GND	Ground
10	GND	Ground
11	MIPI_D2+	MIPI_DP2+ are differential data signal line
12	MIPI_D2-	MIPI_DP2- are differential data signal line
13	GND	Ground
14	MIPI_D1+	MIPI_DP1+ are differential data signal line
15	MIPI_D1-	MIPI_DP1- are differential data signal line
16	GND	Ground.
17	MIPI_CLK+	MIPI_CLOCK Lane positive-end input pin
18	MIPI_CLK-	MIPI_CLOCK Lane engative-end input pin
19	GND	Ground.
20	MIPI_D0+	MIPI_DP0+ are differential data signal line
21	MIPI_D0-	MIPI_DP0- are differential data signal line
22	GND	Ground.
23	MIPI_D3+	MIPI_DP3+ are differential data signal line
24	MIPI_D3-	MIPI_DP3- are differential data signal line
25	GND	Ground.
26	NC	No connect.
27	<b>RESET/NC</b>	<b>Reset signal / Using the RC circuit on the FPC</b>
28	<b>ID</b>	<b>ID PIN, Connect a pull-up resistor to 4.7K.</b>
29	<b>NC</b>	<b>No connect.</b>
30	VDD3V3	Power supper 3.0-3.6 V
31	VDD3V3	Power supper 3.0-3.6 V

## 5.0 Absolute Maximum Ratings

### 5.1 Electrical Absolute Rating

Item	Symbol	Min.	Typ.	Max.	Unit	Note
Power supply	VDD3V3	3.0	3.3	3.6	V	
Input signal voltage	V <sub>IH</sub>	0.7V <sub>DD3V3</sub>	-	V <sub>DD3V3</sub>	V	
	V <sub>IL</sub>	0	-	0.3 V <sub>DD3V3</sub>	V	

### 5.2 Environment Absolute Rating

Item	Symbol	Min.	Max.	Unit	Note
Operating Temperature	T <sub>opa</sub>	-10	50	°C	
Storage Temperature	T <sub>stg</sub>	-20	60	°C	

### 5.3 Back-light Unit:

PARAMETER	Sym.	Min.	Typ.	Max.	Unit	Test Condition	Note
LED Current	I <sub>F</sub>	-	120	-	mA	-	-
LED Voltage	V <sub>LED</sub>	22.8	24	24.5	V	-	-
CTP+LCM Brightness	L	-	510	-	cd/m <sup>2</sup>		
Life Time		20000	--	-	Hr.	I ≤ 120mA	-
Color	White						

Note (1) Permanent damage may occur to the LCD module if beyond this specification. Functional operation should be restricted to the conditions described under normal operating conditions.

(2) T<sub>a</sub>=25±2°C

(3) Test condition: LED Current 120mA

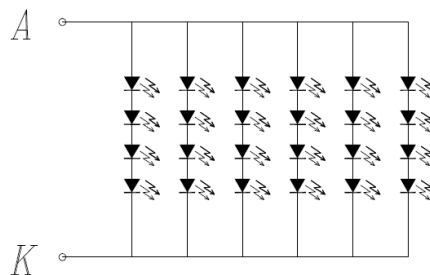

I<sub>F</sub>=120mA, V<sub>F</sub>=24V (TYP)

## 6.0 Optical Characteristics

Item	Symbol	Condition	Min.	Typ.	Max.	Unit	Note
Contrast Ratio	CR	$\Theta=0$	1000	1200	—		(1)(2)(4)
Response time	Tr+ Tf	Normal viewing angle	— -	25	30	msec	(1)(3)
Color chromaticity (CIE1931)	White	$W_x$	-0.030	0.302	+0.030		(1)(4) CF Glass C light
		$W_y$		0.313			
	Red	$R_x$		0.616			
		$R_y$		0.366			
	Green	$G_x$		0.340			
		$G_y$		0.583			
	Blue	$B_x$		0.123			
		$B_y$		0.053			
Viewing angle	Hor.	$\Theta_L$	CR>10	80	85	—	
		$\Theta_R$		80	85	—	
	Ver.	$\Theta_U$		80	85	—	
		$\Theta_D$		80	85	—	
Color Gamut			57	62	--	%	
CTP+LCM Luminous	IV		-	510	--	cd/m <sup>2</sup>	CA310 test
Luminance Uniformity	YU		70	75		%	Note1 9 Point Test

### Note 1: Measurement method

1.1 The LCD module should be stabilized at given temperature for 30 minutes to avoid abrupt temperature change during measuring. In order to stabilize the luminance, the measurement should be executed after lighting .

Backlight for 30 minutes in a stable, windless and dark room, and it should be measured in the center of screen.

### 1.2 Test method : 9 Point Test Location on LCD surface

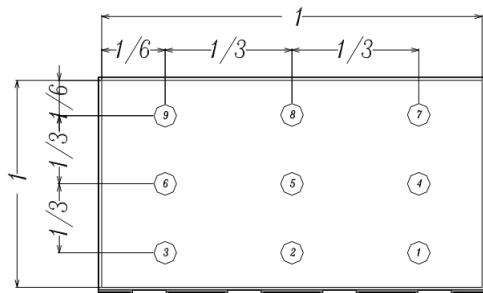

测试取点 请如上图

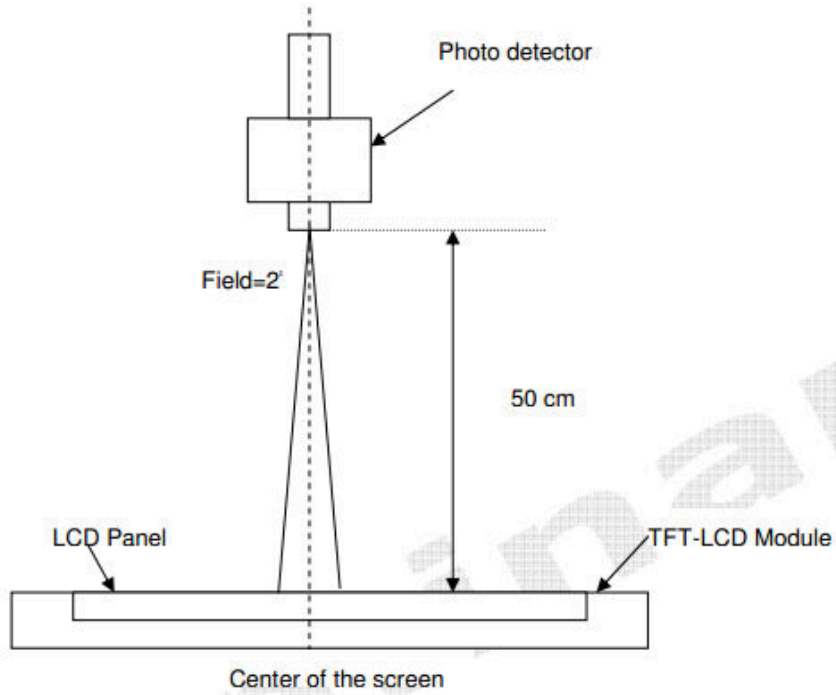

**Note 2:** Definition of Average Luminance of White (YL):

Measure the luminance of gray level 63 at 5 points,  $YL = [L(1) + L(2) + L(3) + L(4) + L(5)] / 5$   
 $L(x)$  is corresponding to the luminance of the point X at Figure in Note (1)

**Note 3:** Definition of contrast ratio:

Contrast ratio is calculated with the following formula.

$$\text{Contrast ratio (CR)} = \frac{\text{Brightness on the "White" state}}{\text{Brightness on the "Black" state}}$$

**Note 4:** Definition of Cross Talk (CT)

$$CT = |Y_B - Y_A| / Y_A \times 100 (\%)$$

Where

$Y_A$  = Luminance of measured location without gray level 0 pattern (cd/m<sup>2</sup>)

$Y_B$  = Luminance of measured location with gray level 0 pattern (cd/m<sup>2</sup>)

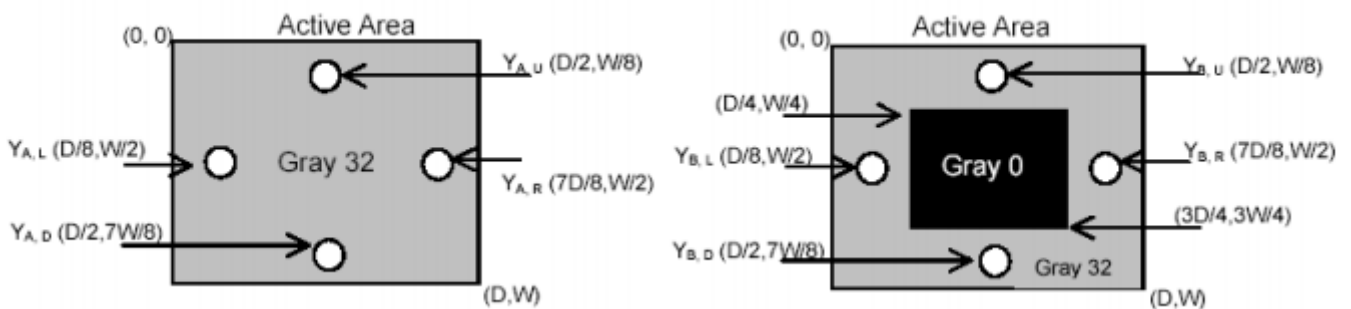

**Note 5:** Definition of response time:

“White” (falling time) and from “White” to “Black” (rising time), respectively. The response time interval between the 10% and 90% of amplitudes. Refer to figure as below.

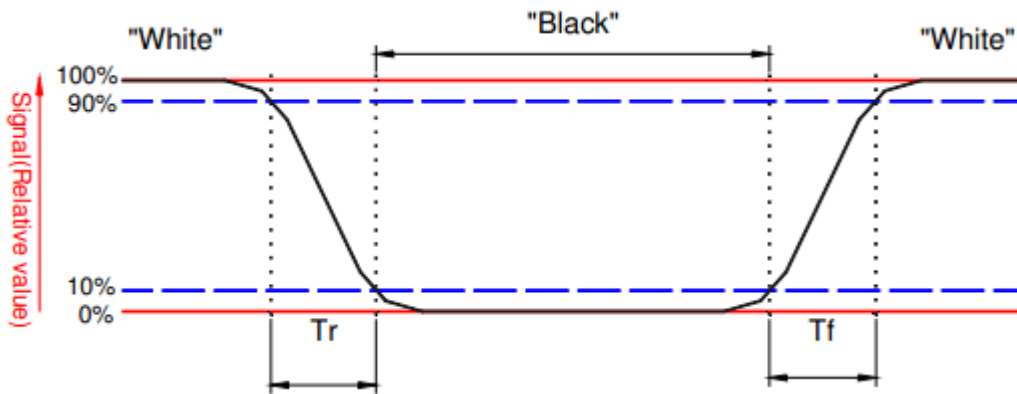

**Note 6.** Definition of viewing angle

Viewing angle is the measurement of contrast ratio  $\geq 10$ , at the screen center, over a  $180^\circ$  horizontal and  $180^\circ$  vertical range (off-normal viewing angles). The  $180^\circ$  viewing angle range is broken down as follows;  $90^\circ$  ( $\theta$ ) horizontal left and right and  $90^\circ$  ( $\Phi$ ) vertical, high (up) and low (down). The measurement direction is typically perpendicular to the display surface with the screen rotated about its center to develop the desired measurement viewing angle.

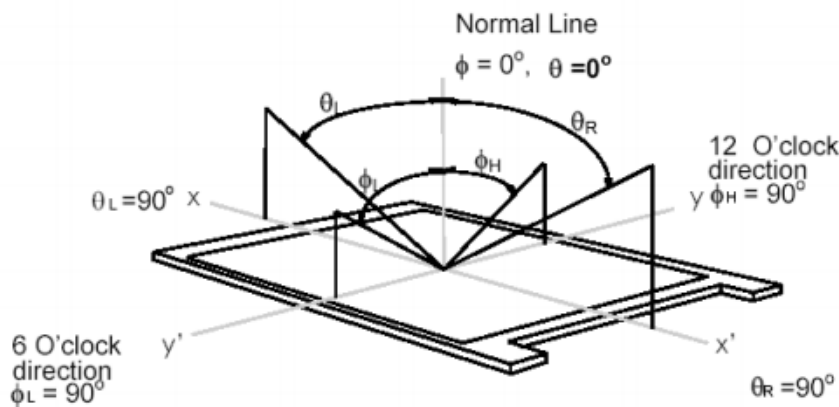

## 7.0 BLOCK DIAGRAM

### Pixel Format

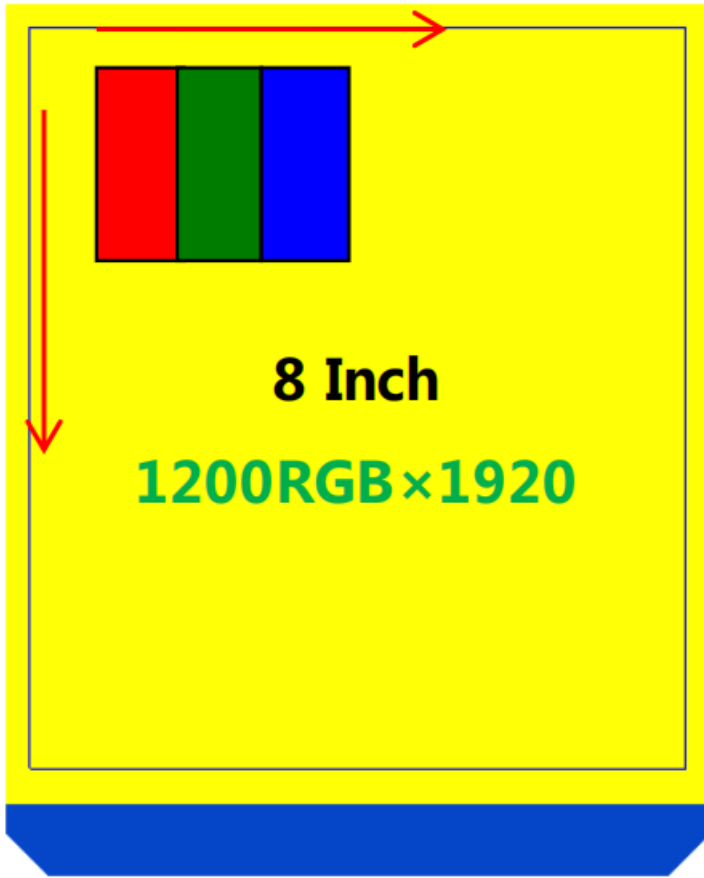

## 7.1 DC Characteristics

Item	Symbol	Min.	Typ.	Max.	Unit
Supply Voltage	VDD3V3	3.0	3.3	3.6	V
	VIH	0.7VDD3V3	-	VDD3V3	V
	VIL	0	-	0.3*VDD3V3	V

## 7.2 MIPI Interface DC characteristic

### HS Receiver DC Specification

Parameter	Symbol	Rating			Unit	Note
		Min	Typ	Max		
Operation Voltage	VDD	1.5-10%	1.5	1.5+10%	mV	
Differential Input Voltage	VID	70	200	260	mV	
Common Mode Voltage	V <sub>CMRX(DC)</sub>	70	-	330	mV	
Differential Input High Threshold Voltage	VTH	-	-	70	mV	
Differential Input Low Threshold Voltage	VTL	-70	-	-	mV	
Singled-ended input high voltage	V <sub>IHHS</sub>	-	-	460	mV	
Singled-ended input low voltage	V <sub>ILHS</sub>	-40	-	-	mV	
Singled-ended threshold for HS termination enable	V <sub>TERM-EN</sub>	-	-	450	mV	
Differential input impedance	Z <sub>ID</sub>	80	100	125	ohm	
Pin leakage current	I <sub>LEAK</sub>	-10	-	10	uA	
Common-mode interference beyond 450MHz	ΔV <sub>CMRX(HF)</sub>	-	-	100	mV	
Common-mode interference 50MHz - 450MHz	ΔV <sub>CMRX(LF)</sub>	-50	-	50	mV	
Common-mode termination	C <sub>CM</sub>	-	-	60	pF	
Embedded Termination	R <sub>T</sub>	90	100	110	ohm	2bits RT_SEL[1: 0] for termination resistor selection 00 → 200ohm 10 , 01 → 150ohm 11 → 100ohm (default)  1bit ERMR_EN for termination resistor enable TERM_EN=0, termr disable R=(OPEN) TERM_EN=1, termr enable

#### Note:

- (1) Excluding possible additional RF interference of 100mV peak sine wave beyond 450MHz.
- (2) This table value includes a ground difference of 50mV between the transmitter and the receiver, the static common-mode level tolerance and variations below 450MHz.

### LP Receiver DC Specification

Parameter	Symbol	Rating			Unit	Note
		Min	Typ	Max		
Logic 1 input voltage	$V_{IH}$	880	-	-	mV	
Logic 0 input voltage, not in ULP State	$V_{IL}$	-	-	550	mV	
Input hysteresis	$V_{HYST}$	25	-	-	mV	

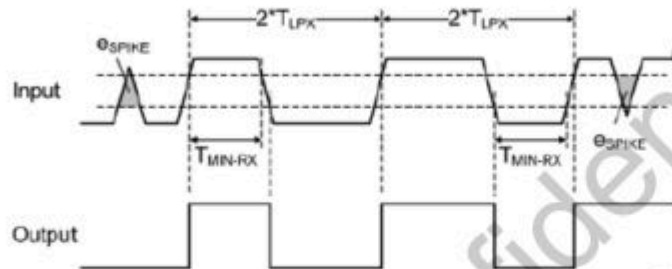

### Line Contention Detection

Parameter	Symbol	Rating			Unit	Note
		Min	Typ	Max		
Logic 1 contention threshold	$V_{IHCD}$	450	-	-	mV	
Logic 0 contention threshold	$V_{ILCD}$	-	-	200	mV	

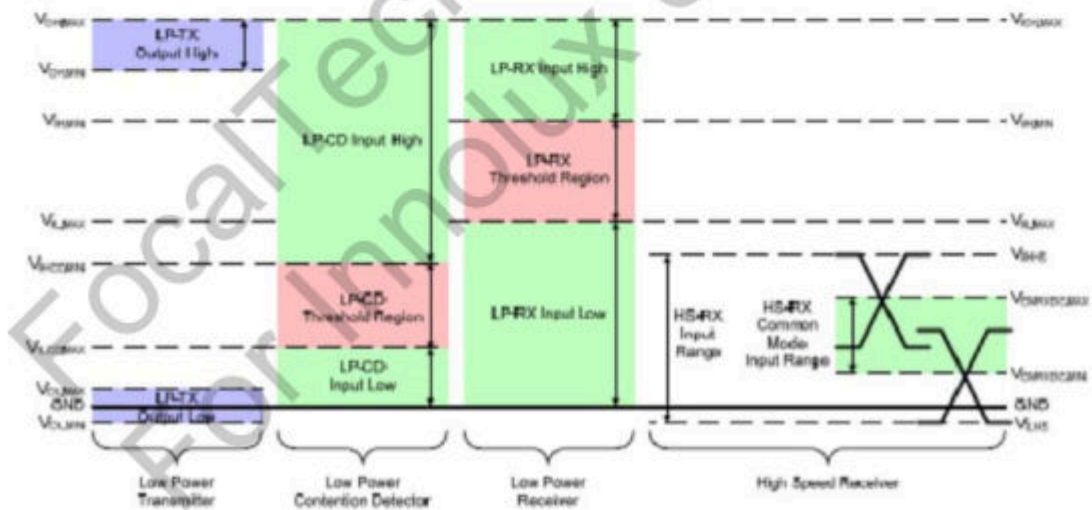

## 7.3 MIPI Interface AC characteristic

### HS Receiver AC Timing Characteristics

Parameter	Symbol	Rating			Unit	Note
		Min	Typ	Max		
Bandwidth per lane	-	-	-	1000	Mbps	Bandwidth selected by register 'speedup' Speedup=0 → Max=550Mbps Speedup=1 → Max=1000Mbps
Operation frequency	-	-	-	500	MHz	
UI instantaneous	$U_{INST}$	1	-	12.5	ns	1
Data to Clock Skew	$T_{skew}$	-0.15	-	0.15	$U_{INST}$	
Inter-lane static skew	$T_{skew-lane}$	-	-	$U_{INST}/50$	$U_{INST}$	
Data to Clock Setup Time	$T_{SETUP}$	0.25	-	-	$U_{INST}$	2
Data to Clock Hold Time	$T_{HOLD}$	0.25	-	-	$U_{INST}$	
Common-mode interference beyond 450MHz	$\Delta V_{CMRX(HF)}$	-	-	100	mV	4
Common-mode interference 50MHz- 450MHz	$\Delta V_{CMRX(LF)}$	-50	-	50	mV	3,6
Common-mode termination	$C_{CM}$	-	-	60	pF	5

Note:

- (1) Total silicon and package delay budget of  $0.3 \cdot U_{INST}$
- (2) Total setup and hold window for receiver of  $0.3 \cdot U_{INST}$
- (3) Excluding 'static' ground shift of 50mV
- (4)  $\Delta V_{CMRX} (HF)$  is the peak amplitude of a sine wave superimposed on the receiver input
- (5) For higher bit rates a 14pF capacitor will be needed to meet the common-mode return loss specification.
- (6) Voltage difference compared to the DC average common-mode potential.

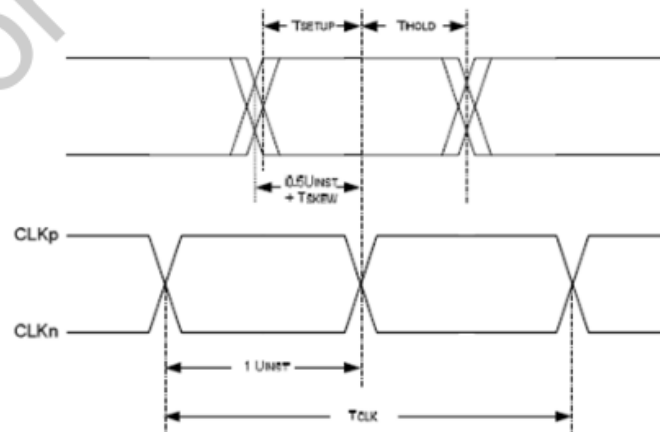

**LP Receiver AC Timing Characteristics**

Parameter	Symbol	Rating			Unit	Note
		Min	Typ	Max		
Input pulse rejection	$e_{\text{SPIKE}}$	-	-	300	V·ps	1,2,3
Minimum pulse width response	$T_{\text{MIN-RX}}$	20	-	-	ns	
Peak interference amplitude	$V_{\text{INT}}$	-	-	200	mV	
Interference frequency	$f_{\text{INT}}$	450	-	-	MHz	
Logic 1 input voltage	$V_{\text{IH}}$	880	-	-	mV	
Logic 0 input voltage, not in ULP State	$V_{\text{IL}}$	-	-	550	mV	
Logic 0 input voltage, ULP State	$V_{\text{IL-ULPS}}$	-	-	300	mV	
Input Hysteresis	$V_{\text{HYST}}$	25	-	-	mV	
Logic 1 contention threshold	$V_{\text{IHCD}}$	450	-	-	mV	
Logic 0 contention threshold	$V_{\text{ILCD}}$	-	-	200	mV	

Note:

- (1) Time-voltage integration of a spike above  $V_{\text{IL}}$  when being in LP-0 state or below  $V_{\text{IH}}$  when being in LP-1state.
- (2) An impulse less than this will not change the receiver state.
- (3) In addition to the required glitch rejection, implementers shall ensure rejection of known RF-interferers.

## 7.4 Power on/off Sequence

### Power-On/Off Timing Sequence:

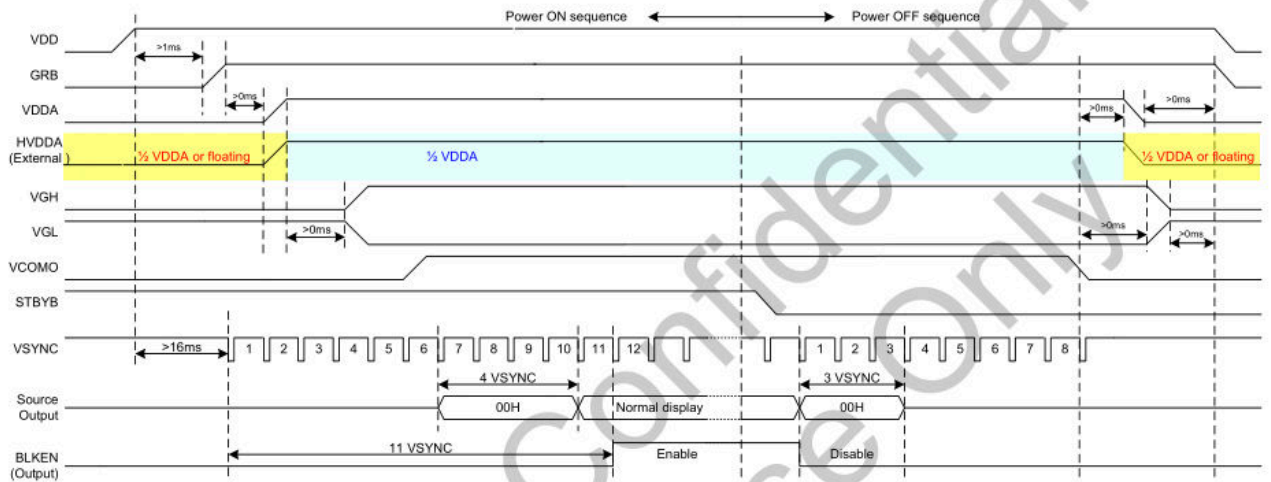

### Enter and Exit Standby Mode Sequence:

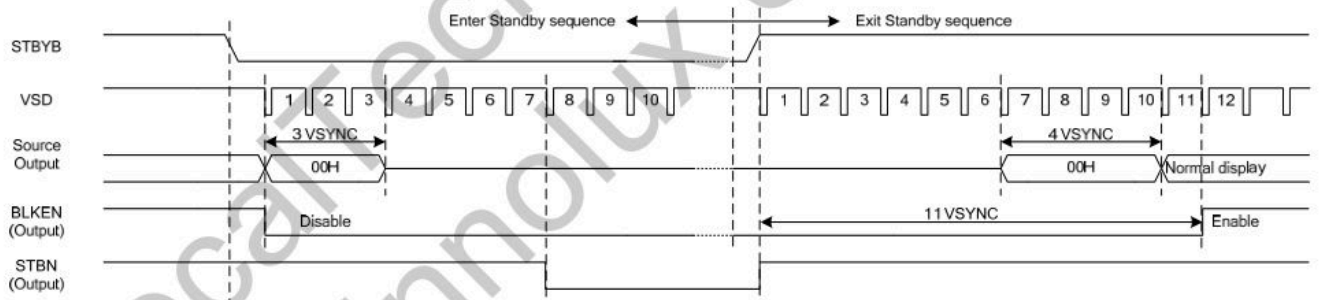

## 7.5 Input Timing(推荐 Porch)

1200RGBx1920 (4 Data Lanes)

Parameter	Symbol	Min.	Typ.	Max.	Unit
MIPI data frequency	FDATA	955	999	1000	Mbps
Horizontal display area	THD	1200			pixel
HS period time	TH	1275	1341	1342	pixel
HS pulse width	THPW	1	1	1	pixel
HS back porch	THBP	32	60	60	pixel
HS front porch	THFP	42	80	81	pixel
Vertical display area	TVD	1920			H
VS period time	TV	1981	1981	1982	H
VS pulse width	TVPW	1	1	1	H
VS back porch	TVBP	25			H
VS front porch	TVFP	35	35	36	H

## 8.0 Reliability test items

NO	Item	Conditions	Remark
1	High Temperature Storage	Ta=+60℃,48hrs	
2	Low Temperature Storage	Ta=-20℃,48hrs	
3	High Temperature Operation	Ta=+50℃,48hrs	
4	Low Temperature Operation	Ta=-10℃,48hrs	
5	High Temperature and High Humidity (non operation)	Ta=+40℃,90%RH,48hrs	
6	Thermal Cycling Test (non operation)	-20℃(0.5hr)→+60℃(30min),27cycles	

Note1: All tests above are practiced at module type.

There is no display function NG issue occurred, All the cosmetic specification is judged before the reliability stress.

Note2:Image sticking Test

### <Measurement Condition>

In general operate condition. (Temp. 25℃)

### <Test Item >

Chess Board pattern(White background and Black square) for 4 hours

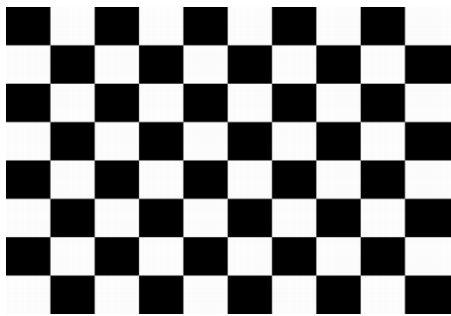

(a)Test pattern(chess board pattern)



(b)Gray pattern (LV128)

### <Judgement Criteria>

Operation with test pattern sustained for 4hrs,then change to gray pattern immediately.after 10 minutes,the mura must be disappeared completely

## 9.0 GENERAL PRECAUTION

### 9.1 Use Restriction

This product is not authorized for use in life supporting systems, aircraft navigation control systems, military systems and any other application where performance failure could be life threatening or otherwise catastrophic.

### 9.2 Disassembling or Modification

Do not disassemble or modify the module. It may damage sensitive parts inside LCD module, and may cause scratches or dust on the display. Manufacturer does not warrant the module, if customers disassemble or modify the module.

### 9.3 Breakage of LCD Panel

9.3.1. If LCD panel is broken and liquid crystal spills out, do not ingest or inhale liquid crystal, and do not contact liquid crystal with skin.

9.3.2. If liquid crystal contacts mouth or eyes, rinse out with water immediately.

9.3.3. If liquid crystal contacts skin or cloths, wash it off immediately with alcohol and rinse thoroughly with water.

9.3.4. Handle carefully with chips of glass that may cause injury, when the glass is broken.

### 9.4 Electric Shock

9.4.1. Disconnect power supply before handling LCD module.

9.4.2. Do not pull or fold the LED cable.

9.4.3. Do not touch the parts inside LCD modules and the fluorescent LED's connector or cables in order to prevent electric shock.

### 9.5 Absolute Maximum Ratings and Power Protection Circuit

9.5.1. Do not exceed the absolute maximum rating values, such as the supply voltage variation, input voltage variation, variation in parts' parameters, environmental temperature, etc., otherwise LCD module may be damaged. 9.5.2. Please do not leave LCD module in the environment of high humidity and high temperature for a long time. 9.5.3. It's recommended to employ protection circuit for power supply.

### 9.6 Operation

9.6.1 Do not touch, push or rub the polarizer with anything harder than HB pencil lead.

9.6.2 Use fingerstalls of soft gloves in order to keep clean display quality, when persons handle the LCD module for incoming inspection or assembly.

9.6.3 When the surface is dusty, please wipe gently with absorbent cotton or other soft material.

9.6.4 Wipe off saliva or water drops as soon as possible. If saliva or water drops contact with polarizer for a long time, they may causes deformation or color fading.

9.6.5 When cleaning the adhesives, please use absorbent cotton wetted with a little petroleum benzine or other adequate solvent.

### 9.7 Mechanism

Please mount LCD module by using mouting holes arranged in four corners tightly.

### 9.8 Static Electricity

9.8.1 Protection film must remove very slowly from the surface of LCD module to prevent from

electrostatic occurrence.

9.8.2. Because LCD module use CMOS-IC on circuit board and TFT-LCD panel, it is very weak to electrostatic discharge. Please be careful with electrostatic discharge. Persons who handle the module should be grounded through adequate methods.

### **9.9 Strong Light Exposure**

The module shall not be exposed under strong light such as direct sunlight. Otherwise, display characteristics may be changed.

### **9.10 Disposal**

When disposing LCD module, obey the local environmental regulations.



## 1.Scope of application /适用范围.

This document shall be applied to 5.5~10.0 inch touch display screen.

本文件适用于5.5~10.0 寸触摸显示屏.

## 2.Inspection conditions and environment /检验条件与环境.

### 2.1 Inspection Conditions /检验条件:

(1) Inspection Distance /检测距离: 35cm ±5cm.

(2) Check time /检验时间:

Displays performance test /功能测试: 2~3S /Image, Cosmetic Inspection /外观检验:10~12S.

(3) Check the viewing angle /检验视角:

Light-on Inspection Angle /点灯检验角度: ±45°.

Cosmetic Inspection Angle /外观检验角度: ±45°.

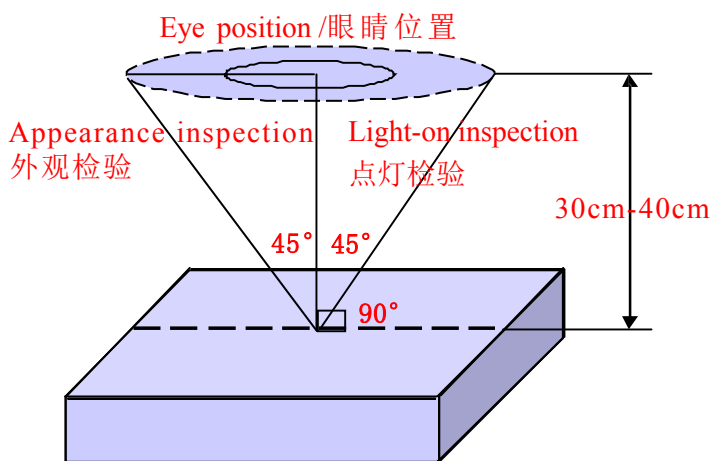

(Perpendicular to LCD panel surface /垂直于LCD表面)

### 2.2 Inspection environment /检验环境:

Ambient Temperature 温度		25°C±5°C
Ambient Humidity 湿度		55±5%RH
Ambient Illumination 亮度	Cosmetic Inspection 外观检验	800-1000 Lux
	Functional Inspection 点灯检验	200~300Lux

### 2.3 Sampling Conditions /抽样条件:

(1) Quantity to be inspected /批量: Quantity of shipment lot per model /单次运送单一型号数量.

(2) Sampling method /抽样方法:

Sampling Plan /抽样计划		GB/T 2828.1- 2003
		Normal Inspection , Single Sampling 正常检验、单次抽样
		General inspection level: II 一般检验水平: 二级
AQL	Major Defect /主要缺陷	0.65
	Minor Defect /次要缺陷	1.0

(3) The classification of Major(MA) and Minor(MI) defects is shown as “3.1 Classification of defects” .  
主缺(MA)及次缺(MI)定义于”3.1 缺陷分类”.

### 3. Terms And Definitions /术语和定义

#### 3.1 Classification of defects / 缺陷分类 :

(1) Major defects /主要缺陷:

A major defect is a defect that is likely to result in failure, or to reduce materially the usability of the product for its intended purpose .

可导致产品功能失效或减少产品可用性的缺陷.

(2) Minor defects /次要缺陷:

It will not cause the product to fail and reduce the defects in the effective use and operation of the product.

不会导致产品功能失效和减少产品的有效使用与操作的缺陷.

#### 3.2 Point defects /点状缺陷:

The size of the point defect is defined by the diameter D, and the average diameter of the defect is

$$D=1/2 (W+L) .$$

点状缺陷的大小是由直径 D 定义的, 缺陷的平均直径  $D=1/2(W+L)$ .

#### 3.3 Linear defects /线状缺陷:

When defect size  $L \geq 2W$ , the defect count as liner type defect. Size of linear defect is defined by length ( L ) and the maximum width ( W ).

当缺陷尺寸  $L \geq 2W$  时, 被视为线状缺陷, 线状缺陷是由长度 (L) 和最大宽度 (W) 定义的.

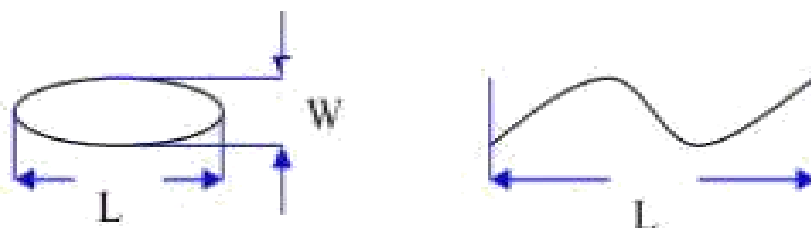

### 3.4 LCD sub-pixel dot /LCD子像素点

(1) Definition /定义 : The point defect area is greater than 50% of the LCD sub-pixel area, and is visible through ND5% filter masking .

子像素点缺陷面积大于 50% LCD子像素面积, 且透过 ND5%遮盖是可见的.

(2) The drawing of 1/2 area sub-pixel definition / 1/2 面积的子像素定义绘图:

The 1/2 area sub-pixel can be defined as below one or more of specific shapes

1/2 面积的子像素可以定义为如下一个或多个特定形状图:



### 3.5 Small bright dot /细碎亮点 :

Point defects smaller than "LCD sub-pixels" /小于“LCD子像素点”的点缺陷.

(Ratio of Zone I to Zone O / I 区与 O 区比例: 1: 2: 1)



### 3.6 ND filter inspection method /ND卡的检验方法:

Hold the ND filter about 5cm above the display area, with your eyes 30-40cm away from the panel, and observe for 2~3 seconds.

在显示区域上方大约 5cm 处握住 ND 卡, 眼睛距离面板 30-40cm, 观察2~3 秒.

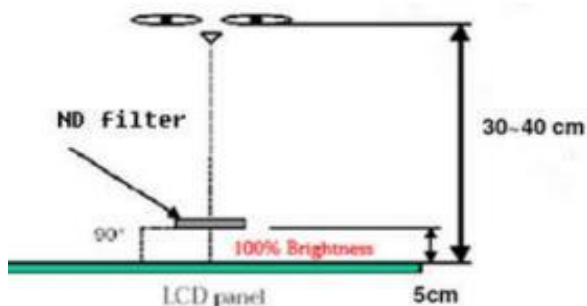

3.7 Any FPC surface problems that do not leak copper on the surface and do not cause functional failure are acceptable.

任何 FPC 表面问题, 表面未露铜和不造成功能失效是可以接受.

3.8 Extraneous substances that can be wiped out , like Finger point,Particles are not considered as a defect .

可以被擦拭干净的表面物质不视为缺陷 (如手指印, 尘粒) .

3.9 Defects that can be covered by the material and are not visible in appearance are not considered defects.

能被物料覆盖，外观不可见的缺陷不视为缺陷。

3.10 Panel damage /面板损伤:

Glass damage outside the AA display area that does not affect the effective wiring is acceptable.

AA 显示区域以外的玻璃损伤，不影响有效线路是可以接受的。

3.11 Issues not specified or defined in this acceptance standard shall be handled through friendly negotiation between the two parties.

本允收标准中未规定或定义的问题，双方友好协商处理。

## 4. Inspection standards /检验标准

### 4.1 Structural Dimensions /结构尺寸规格

Serial Number 序号	Measurement items /测量项目		Specification /规格	Remark /备注
	名称 /Name	Unit /单位	Tolerance /公差	
1	Outside dimension: Length 尺寸: 长	mm /毫米	0.15mm~0.30mm	Please refer to the product specification for detailed dimensions and tolerances 详细的尺寸规格和公差请参考产品规格书
2	Outside dimension: Width 尺寸: 宽	mm /毫米	0.15mm~0.30mm	
3	Outside dimension: Thickness 尺寸: 高	mm /毫米	0.20mm~0.50mm	

### 4.2 Appearance Inspection Specification /外观检验规格

(D : diameter, W : width, L : length, N : quantity, DS : spacing)

Inspection area 检验区域	Inspection items 检验项目	Inspection specifications 检验规格	Defect category 缺陷类别	
Glass 玻璃	Wire(on Array) 线路	Can't be damaged 不能损伤	MA	
	Chipping/corner breaking 崩边/破角	Can't affect the effective lines and functions 不能影响有效线路和功能	MA	
	Edge 边缘	There must be no extensional cracks 不可有延伸性裂纹	MA	
Silicone 硅胶	Silicone coating 硅胶涂布	The height must not exceed the LCD CF surface 高度不能超过LCD CF面		MI
	Glue overflow 溢胶	Can't cover FPC, POL, etc 不能覆盖到FPC、POL等		MI

Inspection area 检验区域	Inspection items 检验项目	Inspection specifications 检验规格	Defect category 缺陷类别	
PCBA  FPC  Connector 连接器	Appearance 外观	Scratches or injuries are not allowed to cause copper exposure 划伤或损伤不允许表面出现露铜		MI
	Component 元器件	Can't be damaged and lack 不能损伤和缺少	MA	
	Goldfinger oxidation 金手指氧化	Not allowed 不允许		MI
	Connection status 连接状况	The connection must be accurate and stable 必须准确稳定连接	MA	
	Break 破裂	Not allowed 不允许	MA	
	Soldering.: false soldering/tinning/tin beads 假焊/连锡/锡珠	Not allowed 不允许	MA	
POL 偏光片	Scratches 划伤	1. $W \leq 0.07\text{mm}$ ; $L \leq 5\text{mm}$ , Ignore (忽略) 2. $0.07\text{mm} < W \leq 0.12\text{mm}$ ; $L \leq 5\text{mm}$ ; $N \leq 4$ ; $DS \geq 10\text{mm}$ 3. $0.12\text{mm} < W$ ; $5\text{mm} < L$ , Not allowable (不允许)		MI
	Dent 凹凸印	1. $D \leq 0.20\text{mm}$ , Ignore (忽略) 2. $0.20\text{mm} < D \leq 0.40\text{mm}$ ; $N \leq 4$ ; $DS \geq 10\text{mm}$ 3. $0.40\text{mm} < D$ , Not allowable (不允许)		MI
	Bubbles 气泡	1. $D \leq 0.20\text{mm}$ , Ignore (忽略) 2. $0.20\text{mm} < D \leq 0.40\text{mm}$ ; $N \leq 4$ ; $DS \geq 10\text{mm}$ 3. $0.40\text{mm} < D$ , Not allowable (不允许)		MI
	Point defects 点状不良	1. $D \leq 0.20\text{mm}$ , Ignore (忽略) 2. $0.20\text{mm} < D \leq 0.40\text{mm}$ ; $N \leq 4$ ; $DS \geq 10\text{mm}$ 3. $0.40\text{mm} < D$ , Not allowable (不允许)		MI
	Edge bubbles 边缘气泡	1. Within 1/2BM of the display area, it is not allowed 显示区往外 1/2BM 区域内, 不允许 2. The display area is 1/2 outside the BM area, and it is not controlled 显示区往外 1/2BM 区域以外, 不管控		MI
	Dirty/watermarked 脏污/水印	No dirt/water lines/finger marks are allowed, and must be wiped clean 不允许有脏污/水纹/手指印, 须擦拭干净方可		MI
	Warping 起翘	Not allowed 不允许		MI
	Attaching offset 贴偏	It is necessary to completely cover the display area outward, within the 1/2BM area, or without leaking POL edges after TP is attached 需完整覆盖显示区往外、1/2BM 区以内或贴合 TP 后不会出现漏偏光片边缘		MI
Mixture 混料	Mixing different types of POL or not using POL as required by the BOM, not allowed 不允许混贴不同型号的 POL 或未按 BOM 要求使用 POL	MA		

Inspection area 检验区域	Inspection items 检验项目	Inspection specifications 检验规格	Defect category 缺陷类别	
TP&CG	Point defects 点状不良	1. $D \leq 0.20\text{mm}$ , Ignore (忽略) 2. $0.20\text{mm} < D \leq 0.40\text{mm}$ ; $N \leq 4$ ; $DS \geq 10\text{mm}$ 3. $0.40\text{mm} < D$ , Not allowable (不允许)		MI
	Scratches 划伤	1. $W \leq 0.07\text{mm}$ ; $L \leq 5\text{mm}$ , Ignore (忽略) 2. $0.07\text{mm} < W \leq 0.12\text{mm}$ ; $L \leq 5\text{mm}$ ; $N \leq 4$ ; $DS \geq 10\text{mm}$ 3. $0.12\text{mm} < W$ ; $5\text{mm} < L$ , Not allowable (不允许) 4. There is a feeling scratch, Not allowable (有感划伤, 不允许)		MI
	Edges and corners cracked 崩角/崩边	1. Product front /产品正面: Edge and corner chipping is not allowed 崩角、崩边不允许 2. Product back /产品背面: $X \leq 0.5$ , $Y \leq 0.5$ , $Z \leq 1/2T$ ; $N \leq 4$ ; $DS \geq 10\text{mm}$		MI
	Silk screen 丝印	The silk screen is clear, complete and correct 丝印清晰、完整、内容正确		MI
	Dirty 脏污	Non-wipeable dirt, not allowed 不可擦拭的脏污, 不允许		MI
	Broken 破损	Not allowable 不允许	MA	
	Ink color aberration 油墨色差	$\Delta E > 1$ , Not allowable (不允许)		MI
	Cover pinholes 针孔	1. $D \leq 0.15\text{mm}$ , $N \leq 4$ , $DS \geq 10\text{mm}$ , allowable 2. $D > 0.15\text{mm}$ , intensive pinholes (密集型针孔), Not allowable (不允许)		MI
	IR holes IR孔	Dirt, deviation, color difference, etc. are not allowed 不允许脏污、偏位、色差等		MI
BL 背光	Backlight separation 背光分离	Not allowable 不允许		MI
	Deformation of rubber iron and rubber frame 胶铁、胶框变形	Use the plug gauge 0.3mm on the flat surface and can snap in and judge NG 在平面上使用塞规0.3mm卡翘曲位置, 能卡进判定NG		MI
	The iron frame is oxidized and not tightened 铁框氧化、卡不紧	Not allowable 不允许		MI
	Backlight sticky solder beads, glue, etc 背面粘锡珠、残胶等	Not allowable 不允许		MI
	Inkjet coding, Barcode, QR code 喷码/条码/二维码	The inkjet coding is clear and complete, the barcode and QR code can be scanned normally, and the content and format match 喷码清晰完整、条码和二维码可正常扫描, 内容和格式相符		MI
	Accessories(protective film, double-sided tape, insulating adhesive, etc.) 辅料(保护膜、双面胶、绝缘胶等)	Defects such as missing pastes, sticking deviations, defects, and fractures are not allowed 不允许有漏贴、贴偏、残缺、断裂等缺陷		MI

## 4.3 Electrical test specifications /电性检查规格

( D : diameter, W : width, L : length, N : quantity, DS : spacing )

Inspection items 检验项目	Inspection specifications 检验规格	Defect category 缺陷类别	
Glass bright spots/dark spots 玻璃亮点/暗点	1. $D \leq 0.20\text{mm}$ , Ignore (忽略) 2. $0.20\text{mm} < D \leq 0.40\text{mm}$ ; $N \leq 4$ ; $DS \geq 10\text{mm}$ 3. $0.40\text{mm} < D$ , Not allowable (不允许)		MI
Mura	Use ND5% filter masking, visual invisibility is OK, 200~300Lux 使用ND5%遮盖, 目视不可见即为OK, 200~300Lux		MI
Small bright dot 细碎亮点	Use ND5% filter masking, visual invisibility is OK 使用ND5%遮盖, 目视不可见即为OK		MI
Light leakage 漏光	1. Use ND5% filter masking, visual invisibility is OK 使用ND5%遮盖, 目视不可见即为OK 2. If necessary, sign off on the sample 必要时, 签限定样		MI
Backlight black/white dots 背光黑点/白点	1. $D \leq 0.20\text{mm}$ , Ignore (忽略) 2. $0.20\text{mm} < D \leq 0.40\text{mm}$ ; $N \leq 4$ ; $DS \geq 10\text{mm}$ 3. $0.40\text{mm} < D$ , Not allowable (不允许)		MI
Linear foreign bodies 线状异物 (异物毛丝等)	1. $W \leq 0.07\text{mm}$ ; $L \leq 5\text{mm}$ , Ignore (忽略) 2. $0.07\text{mm} < W \leq 0.12\text{mm}$ ; $L \leq 5\text{mm}$ ; $N \leq 4$ ; $DS \geq 10\text{mm}$ 3. $0.12\text{mm} < W$ ; $5\text{mm} < L$ , Not allowable (不允许)		MI
Black/White Print 黑印/白印	Use ND5% filter masking, visual invisibility is OK 使用ND5%遮盖, 目视不可见即为OK		MI
The display is uneven 显示不均匀	Use ND5% filter masking, visual invisibility is OK 使用ND5%遮盖, 目视不可见即为OK		MI
The brightness is uneven 亮度不均匀	Brightness uniformity $< 85.0\%$ , Not allowable 亮度均匀性 $< 85.0\%$ , 不允许		MI
Displacement of the membrane 膜材移位	Not allowable 不允许		MI
Interference pattern/Newtonian pattern 干涉纹/牛顿纹	Not allowable 不允许		MI
Display abnormal 显示异常	Not allowable 不允许	MA	
No display 无显示	Not allowable 不允许	MA	
Line/Missing Drawing 线条/缺画	Not allowable 不允许	MA	
Splash screen 闪屏	Not allowable 不允许	MA	
LCD grid LCD网格	Not allowable 不允许	MA	
Afterimage 残影	Not allowable 不允许	MA	
Wrong viewing angle 视角错误	Not allowable 不允许	MA	
No touch 无触摸	Not allowable 不允许	MA	
Touch the jump point 触摸跳点	Not allowable 不允许	MA	
Not sensitive 触摸不灵敏	Not allowable 不允许	MA	