

Shenzhen Leadtek Electronics Co.,Ltd

PRODUCT SPECIFICATION

TFT-LCD MODULE

Module No: LTK101QFHLM59-V0

Preliminary Specification

Approval Specification

| Designed by | Checked by | Approved by |
|-------------|--------------|-------------|
| <i>jona</i> | <i>Jerry</i> | <i>lan</i> |

Final Approval by Customer

| Approved by | Comment |
|-------------|---------|
| | |

※The specification of "TBD" should refer to the measured value of sample . If there is difference between the design specification and measured value, we naturally shall negotiate and agree to solution with customer.

2. General Description

| N0 | Item | Specification | Unit | Remark |
|----|--------------------|-------------------------------|-------|--------|
| 1 | LCD Size | TFT"10.13 | inch | - |
| 2 | Panel Type | TN | - | - |
| 3 | Display Resolution | 1440 x RGB x 1920 | pixel | - |
| 4 | Display mode | Normally White Reflective | - | - |
| 5 | Display colors | 256 Grey by 8bit | - | - |
| 6 | Viewing Direction | 60° / 60° / 60° / 60° | - | - |
| 7 | LCM Module Size | 158.27(H)x 212.43(V) x0.8 (T) | mm | Note |
| 8 | Active Area | 154.37 (H)x 205.82 (V) | mm | Note |
| 9 | Pixel Pitch | 0.1072(H) x 0.1072(V) | mm | - |
| 10 | Weight | TBD | g | - |
| 11 | Driver IC | HX8279D | bit | - |
| 12 | Light Source | - | - | - |
| 13 | Interface | MIPI 4 Lanes | - | - |

3. Mechanical Drawing

Front View

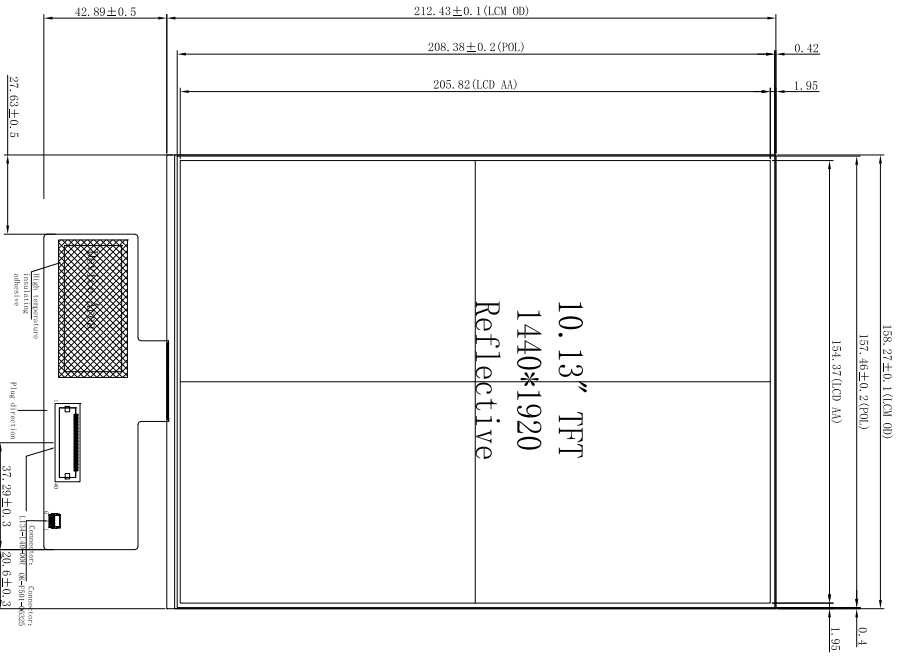

Side View

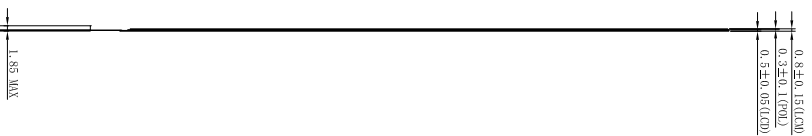

Back View

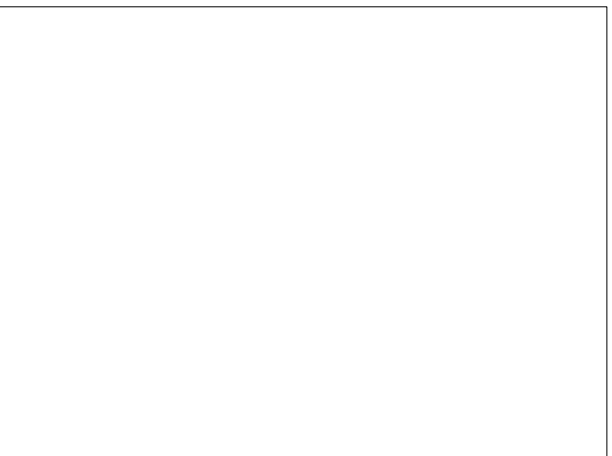

- Notes:
1. Display : 10.13", TFT
 2. Resolution: 1440xRGBx1920
 3. LCD Viewing Direction: 60/60/60/60
 4. Drive IC:HX8279D
 5. Display Mode: Normally White/Reflective/B&W
 6. unmark Tolerance:±0.2
 7. OPERATING TEMP: -20° C ~ +60° C
 8. STORAGE TEMP: -30° C ~ +70° C
 9. Requirements on Environmental Protection: ROHS

| | | | |
|-----|-------------|------------|------|
| 3 | | | |
| 2 | | | |
| 1 | | | |
| 0 | NEW | 2024.10.29 | IAN |
| REV | DESCRIPTION | DATE | NAME |



Shenzhen Leadtek Electronics Co., Ltd

| Pin | DESCRIPTION |
|-----|--------------|
| 1 | GND |
| 2 | D0P |
| 3 | D0N |
| 4 | GND |
| 5 | D1P |
| 6 | D1N |
| 7 | GND |
| 8 | CLKP |
| 9 | CLKN |
| 10 | GND |
| 11 | D2P |
| 12 | D2N |
| 13 | GND |
| 14 | D3P |
| 15 | D3N |
| 16 | GND |
| 17 | GND |
| 18 | VCC-1.8V |
| 19 | VCC-1.8V |
| 20 | CTP-VDD-3.3V |
| 21 | CTP-SDA-1.8V |
| 22 | CTP-SCL-1.8V |
| 23 | CTP-GND |
| 24 | RSTB |
| 25 | STRB(GND) |
| 26 | CTP-INT |
| 27 | GND |
| 28 | K |
| 29 | K |
| 30 | GND |
| 31 | NC |
| 32 | GND |
| 33 | GND |
| 34 | NC |
| 35 | A |
| 36 | A |
| 37 | GND |
| 38 | VDD-3.3V |
| 39 | VDD-3.3V |
| 40 | CTP-RESET |

SCALE: 1/1 UNIT: mm PAGE: 1/1 VER: V0

Part No.: LTK101QPHLMS9 Approve: Kevin

Customer No.: Drawn: JOMA

4. Interface Pin Connection

| NO | Symbol | Function |
|----|-------------|---|
| 1 | GND | Power ground. |
| 2 | MIPI_D0+ | MIPI_DP0+ are differential data signal line |
| 3 | MIPI_D0- | MIPI_DP0- are differential data signal line |
| 4 | GND | Power ground. |
| 5 | MIPI_D1+ | MIPI_DP1+ are differential data signal line |
| 6 | MIPI_D1- | MIPI_DP1- are differential data signal line |
| 7 | GND | Power ground. |
| 8 | MIPI_CLK+ | CLOCK Lane positive-end input pin |
| 9 | MIPI_CLK- | CLOCK Lane engative-end input pin |
| 10 | GND | Power ground. |
| 11 | MIPI_D2+ | MIPI_DP2+ are differential data signal line |
| 12 | MIPI_D2- | MIPI_DP2- are differential data signal line |
| 13 | GND | Power ground. |
| 14 | MIPI_D3+ | MIPI_DP3+ are differential data signal line |
| 15 | MIPI_D3- | MIPI_DP3- are differential data signal line |
| 16 | GND | Power ground. |
| 17 | GND | Power ground. |
| 18 | IOVCC(1.8V) | A supply voltage to the digital circuit. (1.8V) |
| 19 | IOVCC(1.8V) | A supply voltage to the digital circuit. (1.8V) |
| 20 | TP-VDD | Not connect |
| 21 | TP-SDA | Not connect |
| 22 | TP-SCL | Not connect |
| 23 | TP-GND | Not connect |
| 24 | RSTB | Reset signal (Low: Active). |
| 25 | STBYB | Not connect |
| 26 | TP-INT | Not connect |
| 27 | GND | Power ground. |
| 28 | LED- | LED cathode. |



| | | |
|----|-----------|---|
| 29 | LED- | LED cathode. |
| 30 | GND | Power ground. |
| 31 | NC | Not connect |
| 32 | GND | Power ground. |
| 33 | GND | Power ground. |
| 34 | NC | Not connect |
| 35 | LED+ | LED anode. |
| 36 | LED+ | LED anode. |
| 37 | GND | Power ground. |
| 38 | VCC(3.3V) | A supply voltage to the digital circuit. (3.3V) |
| 39 | VCC(3.3V) | A supply voltage to the digital circuit. (3.3V) |
| 40 | TP-RESET | Not connect |



5.0 LCM DC CHARACTERISTICS

(Ta=25±2°C)

| Characteristics | Symbol | Min. | Typ. | Max. | Unit | Note |
|------------------------|--------|------|------|------|------|------|
| Power Supply Voltage 1 | IOVCC | 1.65 | 1.8 | 2.0 | V | |
| Power Supply Voltage 2 | VCI | 2.5 | 2.8 | 3.6 | V | |

5.1 Power on/off sequence

5.1.1 Power on sequence PWRMD=0 → Max. Power on time=7.0VS

After reset state or exit STB mode, the power on sequence will start.

To prevent the device from damage due to latch up, The VGL will be earlier than VGH. At 2.25VS the VGL negative high voltage will be generated via the external charge pump circuit. Then at 2.5VS the VGH positive high voltage can be generated via the external charge pump circuit. One SCHOTTKY diode is necessary between VGL and GND when VDD and VSP start at the same time.

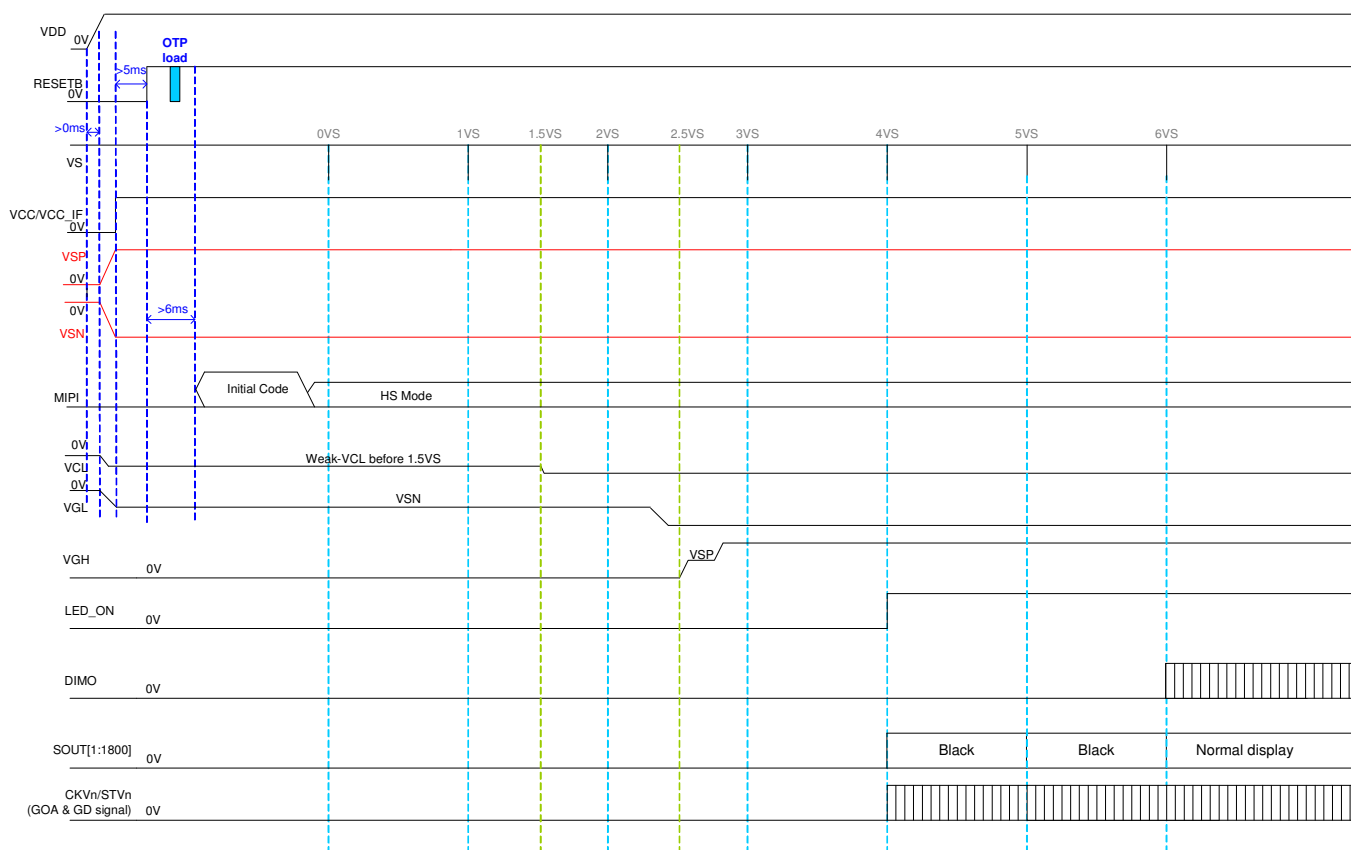

Note: (1) Finish to write the GOA MUX (page1 registers) and GOA timing setting (page3 registers) within 50ms after reset pulls to high.

Figure 5.5: Power on sequence with PWRMD=0 and repair OP disable

5.1.2 Power off sequence PWRMD=0 → Max. Power off time=5.0VS

When enter STB mode, the STBYB signal will be set to low. The power off sequence will start.

Power-off sequence External VSP/VSN. Internal VGH/VGL.

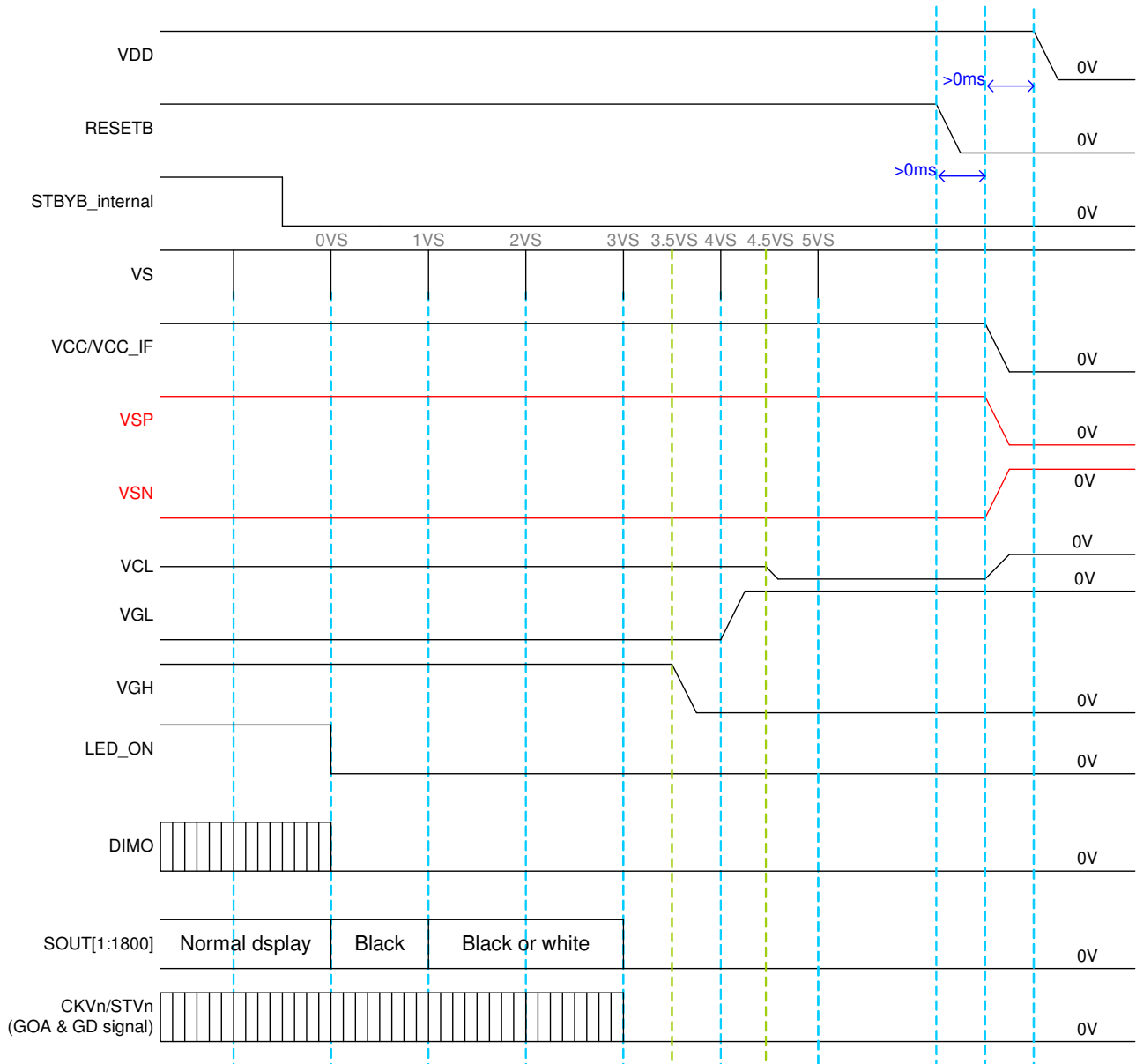
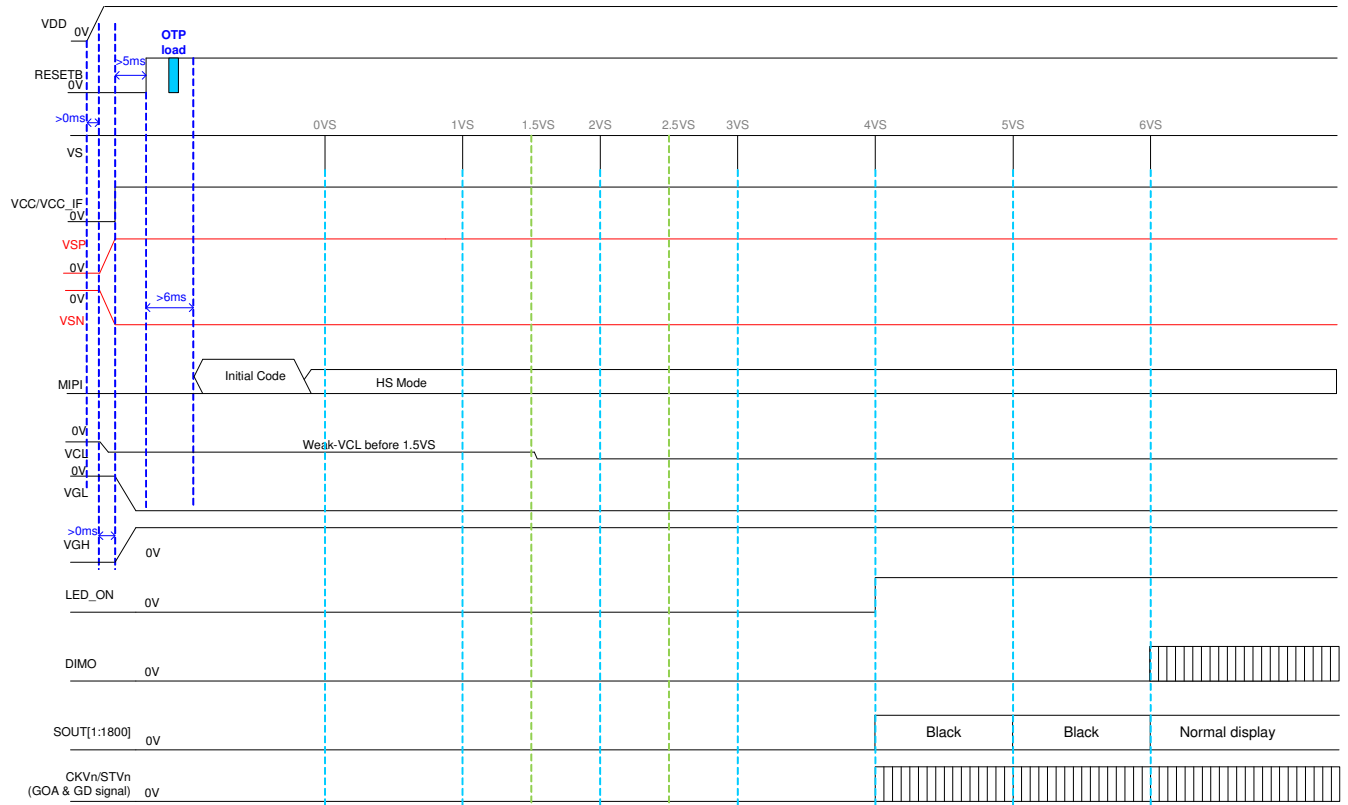

Figure 5.6: Power off sequence with PWRMD=0

5.1.3 Power on sequence PWRMD=1 → Max. Power on time=6.0VS

After reset state or exit STB mode, the power on sequence will start. One SCHOTTKY diode is necessary between VGL and GND when VDD and VSP start at the same time.



Note: (1) Finish to write the GOA MUX (page1 registers) and GOA timing setting (page3 registers) within 50ms after reset pulls to high

Figure 5.7: Power on sequence with PWRMD=1 and repair OP disable

5.1.4 Power off sequence PWRMD=1 → Max. Power off time=4.5VS

When enter STB mode, the STBYB signal will be set to low then the power off sequence will start.

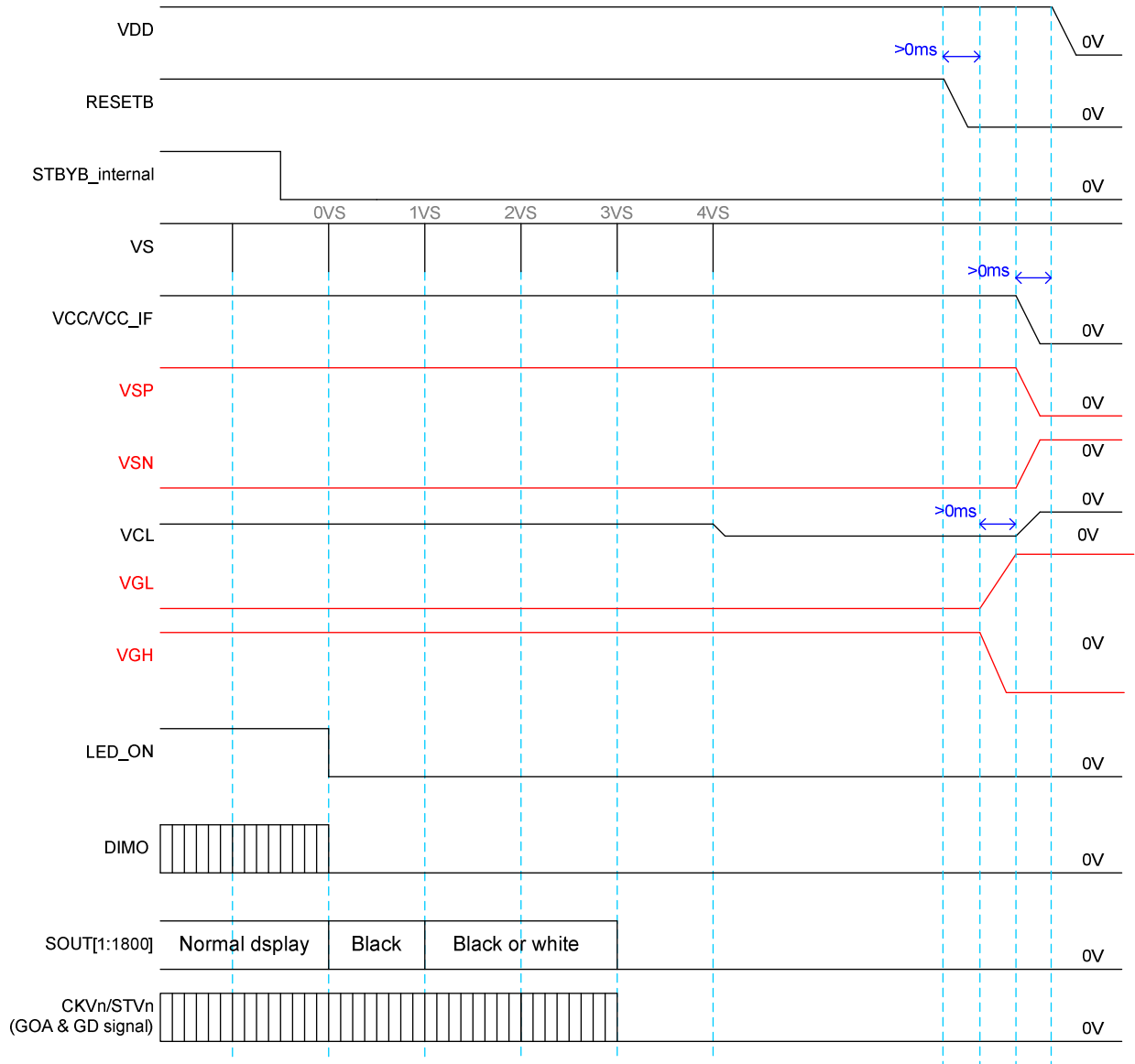

Figure 5.8: Power off sequence with PWRMD=1

6.0 OPTICAL CHARACTERISTICS

6.1 Optical Specification

(Reflective, w/HSD FOG+D65 light)

| Item | Symbol | Condition | Min. | Typ. | Max. | Unit | Note |
|---------------------------------------|--------|--|------|---------|------|------|--|
| White Reflectance (with Polarizer) | Rw (%) | $\Theta=0$ Normal viewing angle | — | 43.05 | — | % | (4) Measuring with HSD polarizer , Reference Only Base on Vop=4.5V |
| Contrast Ratio | CR | — | — | 15 | — | — | (1)(2) Base on Vop=4.5V |
| Color Chromaticity (CIE1931) | White | W_x | — | (0.300) | — | — | (1)(4) Measuring with HSD polarizer , Reference Only |
| | | W_y | — | (0.330) | — | | |
| Viewing Angle | Hor. | Θ_L | — | 60 | — | — | (1)(4) Measuring with HSD polarizer , Reference Only |
| | | Θ_R | — | 60 | — | | |
| | Ver. | Θ_U | — | 60 | — | | |
| | | Θ_D | — | 60 | — | | |

6.2 Measuring Condition

- Measuring surrounding : dark room
- Ambient temperature : $25\pm 2^{\circ}\text{C}$
- 15min. warm-up time.

6.3 Measuring Equipment

- DMS (DMS = Display Measurement System) of AUTRONIC-MELCHERS GmbH, motorized goniometer system for comprehensive display characterization

Note (1) Definition of Viewing Angle:

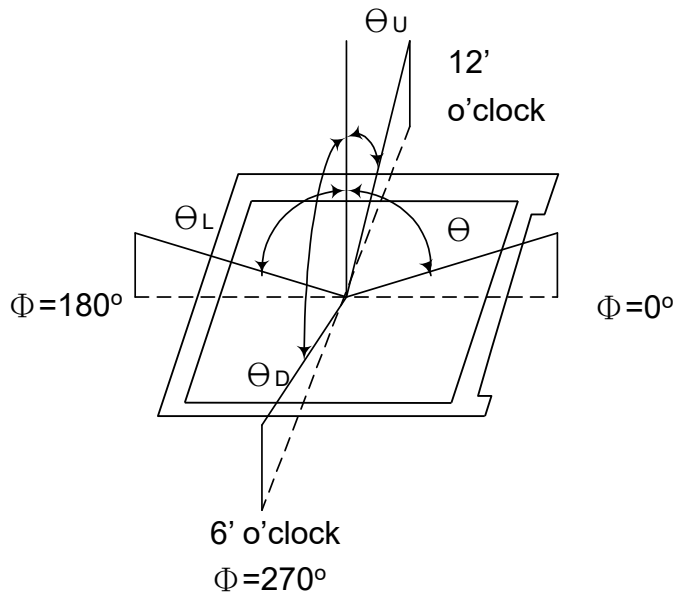

Note (2) Definition of Contrast Ratio (CR) :
measured at the center point of panel

$$\text{CR} = \frac{\text{Luminance with all pixels white}}{\text{Luminance with all pixels black}}$$

Note (3) Definition of Response Time : Sum of T_R and T_F

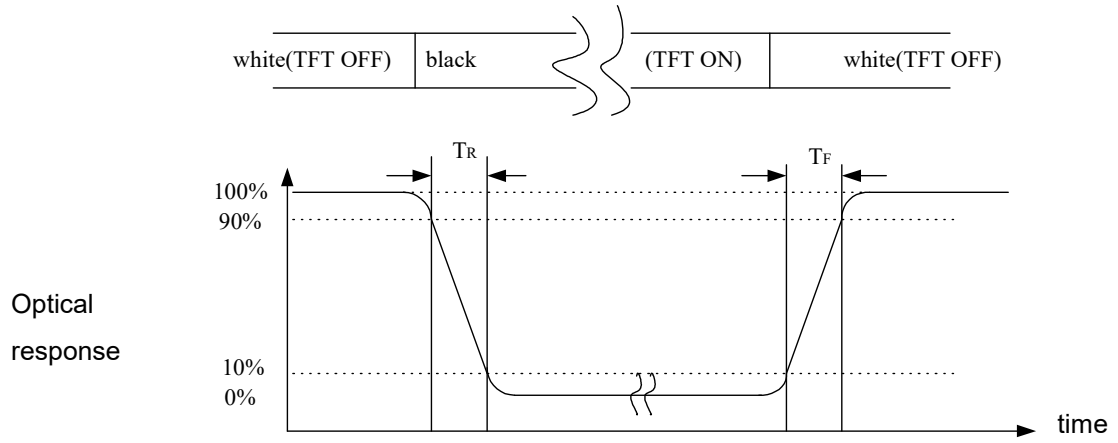

Note (4) Definition of optical measurement setup

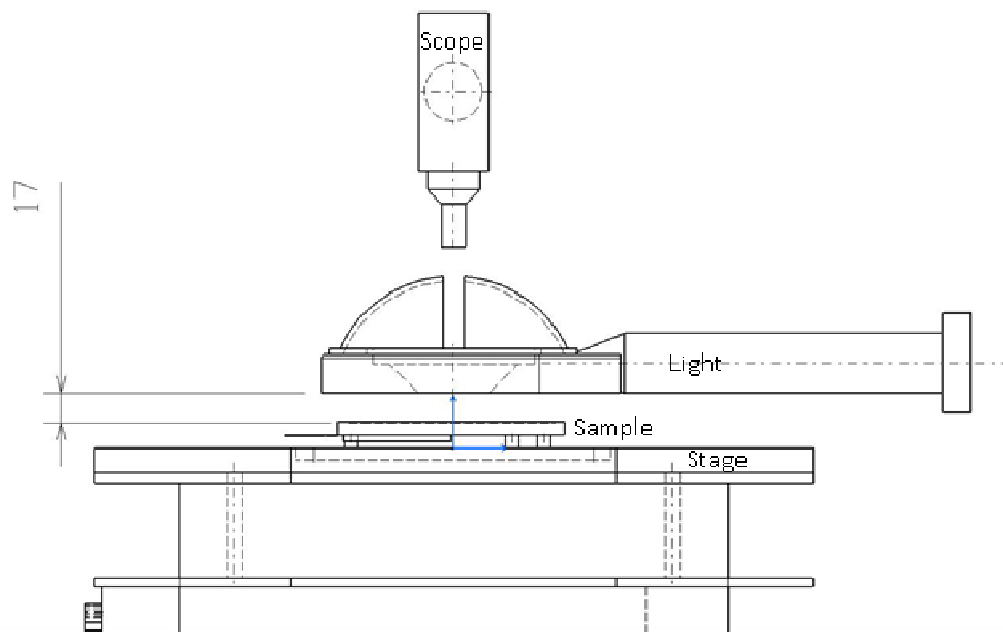

7. Reliability test items

| No. | Test Item | Test Condition | Notes |
|-----|------------------------------------|--|--|
| 1 | High Temp. Storage | +70°C / 48H | 1. Functional test isOK. Missing Segment,short, unclear segment non-display,display abnormally and liquid crystal leakare un-allowed. 2. No low temperature bubbles,end seal loose andfall, frame rainbow. |
| 2 | Low Temp. Storage | -30°C / 48H | |
| 3 | High Tempe. Operating | +60°C / 48H | |
| 4 | Low Tempe. Operating | -20°C / 48H | |
| 5 | High Temperature /Humidity storage | 50°C x 90%RH /48H | |
| 6 | Thermal and cold shock | Static state, -20°C (30min) ~60°C (30min), 50 cycles | |
| 7 | ESD test | ±2KV,Human Body Mode, 150pF/330Ω; ±4KV, Air Mode, 150pF/330Ω; | |

Note: All tests above are practiced at module type.

There is no display function NG issue occurred, All the cosmetic specification is judged before the reliability stress.

8.0 General Precaution

8.1 Use Restriction

This product is not authorized for use in life supporting systems, aircraft navigation control systems, military systems and any other application where performance failure could be life-threatening or otherwise catastrophic.

8.2 Assembly Precaution

- 1、 Please use the mounting hole on the module side in installing and do not bending or wrenching LCD in assembling. And please do not drop, bend or twist LCD module in handling.
- 2、 Please design display housing in accordance with the following guide lines.
- 3、 Housing case must be destined carefully so as not to put stresses on LCD all sides and not to wrench module. The stresses may cause non-uniformity even if there is no non-uniformity statically.
- 4、 Keep sufficient clearance between LCD module back surface and housing when the LCD module is mounted. The clearance in the design is recommended taking into account the tolerance of LCD module thickness and mounting structure height on the housing.
- 5、 Please do not push or scratch LCD panel surface with any-thing hard. And do not soil LCD panel surface by touching with bare hands. (Polarizer film, surface of LCD panel is easy to be flawed.)
- 6、 Please do not press any parts on the rear side such as source IC, gate IC, and FPC during handling LCD module. If pressing rear part is unavoidable, handle the LCD module with care not to damage them.
- 7、 Please wipe out LCD panel surface with absorbent cotton or soft cloth in case of it being soiled.
- 8、 Please wipe out drops of adhesives like saliva and water on LCD panel surface immediately. They might damage to cause panel surface variation and color change. 11.2.7 Please do not take a LCD module to pieces and reconstruct it. Resolving and reconstructing modules may cause them not to work well.

8.3 Disassembling or Modification

Do not disassemble or modify the module. It may damage sensitive parts inside LCD module, and may cause scratches or dust on the display. Leadtek does not warrant the module, if customers disassemble or modify the module.

8.4 Breakage of LCD Panel

- 1、 If LCD panel is broken and liquid crystal spills out, do not ingest or inhale liquid crystal, and do not contact liquid crystal with skin.
- 2、 If liquid crystal contacts mouth or eyes, rinse out with water immediately.
- 3、 If liquid crystal contacts skin or cloths, wash it off immediately with alcohol and rinse thoroughly with water.
- 4、 Handle carefully with chips of glass that may cause injury, when the glass is broken.

8.5 Absolute Maximum Ratings and Power Protection Circuit

- 1、 Do not exceed the absolute maximum rating values, such as the supply voltage variation, input voltage variation, variation in parts' parameters, environmental temperature, etc., otherwise LCD module may be damaged.
- 2、 Please do not leave LCD module in the environment of high humidity and high temperature for a long time.
- 3、 It's recommended employing protection circuit for power supply.

11.6 Operation

- 1、 Do not touch, push or rub the polarizer with anything harder than HB pencil lead. Use fingerstalls of soft gloves in order to keep clean display quality, when persons handle the LCD module for incoming inspection or assembly.
- 2、 When the surface is dusty, please wipe gently with absorbent cotton or other soft material.
- 3、 Wipe off saliva or water drops as soon as possible. If saliva or water drops contact with polarizer for a long time, they may causes deformation or color fading.
- 4、 When cleaning the adhesives, please use absorbent cotton wetted with a little petroleum benzine or other adequate solvent.

8.6 Static Electricity

- 1、 Protection film must remove very slowly from the surface of LCD module to prevent from electrostatic occurrence.
- 2、 Because LCD module uses CMOS-IC on TFT-LCD panel, it is very weak to electrostatic discharge. Please be careful with electrostatic discharge.
- 3、 Persons who handle the module should be grounded through adequate methods.

8.7 Disposal

When disposing LCD module, obey the local environmental regulations.

8.8 OTHERS

- 1、 A strong incident light into LCD panel might cause display characteristics' changing inferior because of polarizer film, color filter, and other materials becoming inferior. Please do not expose LCD module direct sunlight land strong UV rays.
- 2、 Please pay attention to a panel side of LCD module not to contact with other materials in preserving it alone.
- 3、 For the packaging box, please pay attention to the followings:
- 4、 Packaging box and inner case for LCD are designed to protect the LCDs from the damage or scratching during transportation. Please do not open except picking LCDs up from the box.
- 5、 Please do not pile them up more than 6 boxes. (They are not designed so.) And please do not turn over.
- 6、 Please handle packaging box with care not to give them sudden shock and vibrations. And also please do not throw them up.
- 7、 Packing box and inner case for LCDs are made of cardboard. So please pay attention not to get them wet. (Such like keeping them in high humidity or wet place can occur getting them wet.)

9.0 Packing form-TBD

1.Scope of application /适用范围.

This document shall be applied to more than 10.0 inches touch display screen.

本文件适用于5.5~10.0 寸触摸显示屏.

2.Inspection conditions and environment /检验条件与环境.

2.1 Inspection Conditions /检验条件:

(1) Inspection Distance /检测距离: 35cm ±5cm.

(2) Check time /检验时间:

Displays performance test /功能测试: 3~5S /Image, Cosmetic Inspection /外观检验:12~15S.

(3) Check the viewing angle /检验视角:

Light-on Inspection Angle /点灯检验角度: ±45°.

Cosmetic Inspection Angle /外观检验角度: ±45°.

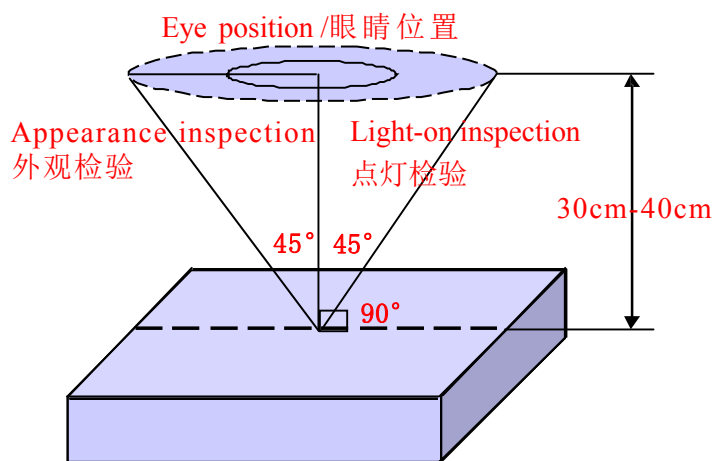

(Perpendicular to LCD panel surface /垂直于LCD表面)

2.2 Inspection environment /检验环境:

| | | |
|----------------------------|-------------------------------|--------------|
| Ambient Temperature 温度 | | 25°C±5°C |
| Ambient Humidity 湿度 | | 55±5%RH |
| Ambient Illumination 亮度 | Cosmetic Inspection 外观检验 | 800-1000 Lux |
| | Functional Inspection 点灯检验 | 200~300Lux |

2.3 Sampling Conditions /抽样条件:

(1) Quantity to be inspected /批量: Quantity of shipment lot per model /单次运送单一型号数量.

(2) Sampling method /抽样方法:

| | | |
|---------------------|--------------------|--|
| Sampling Plan /抽样计划 | | GB/T 2828.1- 2003 |
| | | Normal Inspection , Single Sampling 正常检验、单次抽样 |
| | | General inspection level: II 一般检验水平: 二级 |
| AQL | Major Defect /主要缺陷 | 0.65 |
| | Minor Defect /次要缺陷 | 1.0 |

(3) The classification of Major(MA) and Minor(MI) defects is shown as “3.1 Classification of defects” .
主缺(MA)及次缺(MI)定义于”3.1 缺陷分类”.

3. Terms And Definitions /术语和定义

3.1 Classification of defects / 缺陷分类 :

(1) Major defects /主要缺陷:

A major defect is a defect that is likely to result in failure, or to reduce materially the usability of the product for its intended purpose .

可导致产品功能失效或减少产品可用性的缺陷.

(2) Minor defects /次要缺陷:

It will not cause the product to fail and reduce the defects in the effective use and operation of the product.

不会导致产品功能失效和减少产品的有效使用与操作的缺陷.

3.2 Point defects /点状缺陷:

The size of the point defect is defined by the diameter D, and the average diameter of the defect is

$$D=1/2 (W+L) .$$

点状缺陷的大小是由直径 D 定义的, 缺陷的平均直径 $D=1/2(W+L)$.

3.3 Linear defects /线状缺陷:

When defect size $L \geq 2W$, the defect count as liner type defect. Size of linear defect is defined by length (L) and the maximum width (W).

当缺陷尺寸 $L \geq 2W$ 时, 被视为线状缺陷, 线状缺陷是由长度 (L) 和最大宽度 (W) 定义的.

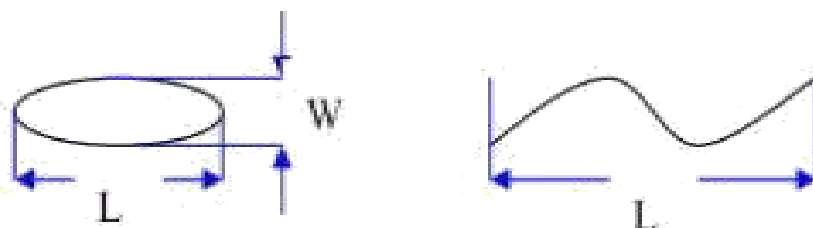

3.4 LCD sub-pixel dot /LCD子像素点

(1) Definition /定义 : The point defect area is greater than 50% of the LCD sub-pixel area, and is visible through ND5% filter masking .

子像素点缺陷面积大于 50% LCD子像素面积, 且透过 ND5%遮盖是可见的.

(2) The drawing of 1/2 area sub-pixel definition / 1/2 面积的子像素定义绘图:

The 1/2 area sub-pixel can be defined as below one or more of specific shapes

1/2 面积的子像素可以定义为如下一个或多个特定形状图:



3.5 Small bright dot /细碎亮点 :

Point defects smaller than "LCD sub-pixels" /小于“LCD子像素点”的点缺陷.

(Ratio of Zone I to Zone O / I 区与 O 区比例: 1: 2: 1)

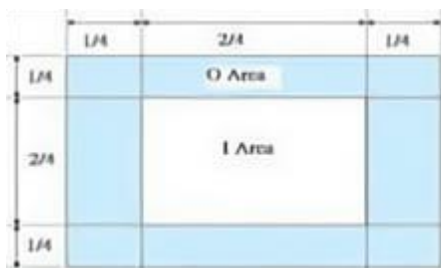

3.6 ND filter inspection method /ND卡的检验方法:

Hold the ND filter about 5cm above the display area, with your eyes 30-40cm away from the panel, and observe for 2~3 seconds.

在显示区域上方大约 5cm 处握住 ND 卡, 眼睛距离面板 30-40cm, 观察2~3 秒.

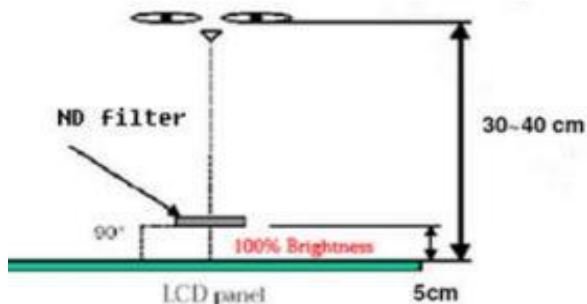

3.7 Any FPC surface problems that do not leak copper on the surface and do not cause functional failure are acceptable.

任何 FPC 表面问题, 表面未露铜和不造成功能失效是可以接受.

3.8 Extraneous substances that can be wiped out , like Finger point,Particles are not considered as a defect .

可以被擦拭干净的表面物质不视为缺陷 (如手指印, 尘粒) .

3.9 Defects that can be covered by the material and are not visible in appearance are not considered defects.

能被物料覆盖，外观不可见的缺陷不视为缺陷。

3.10 Panel damage /面板损伤:

Glass damage outside the AA display area that does not affect the effective wiring is acceptable.

AA 显示区域以外的玻璃损伤，不影响有效线路是可以接受的。

3.11 Issues not specified or defined in this acceptance standard shall be handled through friendly negotiation between the two parties.

本允收标准中未规定或定义的问题，双方友好协商处理。

4. Inspection standards /检验标准

4.1 Structural Dimensions /结构尺寸规格

| Serial Number 序号 | Measurement items /测量项目 | | Specification /规格 | Remark /备注 |
|---------------------|---------------------------------------|----------|-------------------|--|
| | 名称 /Name | Unit /单位 | Tolerance /公差 | |
| 1 | Outside dimension: Length 尺寸: 长 | mm /毫米 | 0.15mm~0.30mm | Please refer to the product specification for detailed dimensions and tolerances 详细的尺寸规格和公差请参考产品规格书 |
| 2 | Outside dimension: Width 尺寸: 宽 | mm /毫米 | 0.15mm~0.30mm | |
| 3 | Outside dimension: Thickness 尺寸: 高 | mm /毫米 | 0.30mm~0.50mm | |

4.2 Appearance Inspection Specification /外观检验规格

(D : diameter, W : width, L : length, N : quantity, DS : spacing)

| Inspection area 检验区域 | Inspection items 检验项目 | Inspection specifications 检验规格 | Defect category 缺陷类别 | |
|-------------------------|-----------------------------------|--|-------------------------|----|
| Glass 玻璃 | Wire(on Array) 线路 | Can't be damaged 不能损伤 | MA | |
| | Chipping/corner breaking 崩边/破角 | Can't affect the effective lines and functions 不能影响有效线路和功能 | MA | |
| | Edge 边缘 | There must be no extensional cracks 不可有延伸性裂纹 | MA | |
| Silicone 硅胶 | Silicone coating 硅胶涂布 | The height must not exceed the LCD CF surface 高度不能超过LCD CF面 | | MI |
| | Glue overflow 溢胶 | Can't cover FPC, POL, etc 不能覆盖到FPC、POL等 | | MI |

| Inspection area 检验区域 | Inspection items 检验项目 | Inspection specifications 检验规格 | Defect category 缺陷类别 | |
|---|---|--|-------------------------|----|
| PCBA FPC Connector 连接器 | Appearance 外观 | Scratches or injuries are not allowed to cause copper exposure 划伤或损伤不允许表面出现露铜 | | MI |
| | Component 元器件 | Can't be damaged and lack 不能损伤和缺少 | MA | |
| | Goldfinger oxidation 金手指氧化 | Not allowed 不允许 | | MI |
| | Connection status 连接状况 | The connection must be accurate and stable 必须准确稳定连接 | MA | |
| | Break 破裂 | Not allowed 不允许 | MA | |
| | Soldering.: false soldering/tinning/tin beads 假焊/连锡/锡珠 | Not allowed 不允许 | MA | |
| POL 偏光片 | Scratches 划伤 | 1. $W \leq 0.10\text{mm}$; $L \leq 5\text{mm}$, Ignore (忽略) 2. $0.10\text{mm} < W \leq 0.15\text{mm}$; $L \leq 5\text{mm}$; $N \leq 5$; $DS \geq 10\text{mm}$ 3. $0.15\text{mm} < W$; $5\text{mm} < L$, Not allowable (不允许) | | MI |
| | Dent 凹凸印 | 1. $D \leq 0.25\text{mm}$, Ignore (忽略) 2. $0.25\text{mm} < D \leq 0.50\text{mm}$; $N \leq 5$; $DS \geq 10\text{mm}$ 3. $0.50\text{mm} < D$, Not allowable (不允许) | | MI |
| | Bubbles 气泡 | 1. $D \leq 0.25\text{mm}$, Ignore (忽略) 2. $0.25\text{mm} < D \leq 0.50\text{mm}$; $N \leq 5$; $DS \geq 10\text{mm}$ 3. $0.50\text{mm} < D$, Not allowable (不允许) | | MI |
| | Point defects 点状不良 | 1. $D \leq 0.25\text{mm}$, Ignore (忽略) 2. $0.25\text{mm} < D \leq 0.50\text{mm}$; $N \leq 5$; $DS \geq 10\text{mm}$ 3. $0.50\text{mm} < D$, Not allowable (不允许) | | MI |
| | Edge bubbles 边缘气泡 | 1. Within 1/2BM of the display area, it is not allowed 显示区往外 1/2BM 区域内, 不允许 2. The display area is 1/2 outside the BM area, and it is not controlled 显示区往外 1/2BM 区域以外, 不管控 | | MI |
| | Dirty/watermarked 脏污/水印 | No dirt/water lines/finger marks are allowed, and must be wiped clean 不允许有脏污/水印/手指印, 须擦拭干净方可 | | MI |
| | Warping 起翘 | Not allowed 不允许 | | MI |
| | Attaching offset 贴偏 | It is necessary to completely cover the display area outward, within the 1/2BM area, or without leaking POL edges after TP is attached 需完整覆盖显示区往外、1/2BM 区以内或贴合 TP 后不会出现漏偏光片边缘 | | MI |
| Mixture 混料 | Mixing different types of POL or not using POL as required by the BOM, not allowed 不允许混贴不同型号的 POL 或未按 BOM 要求使用 POL | MA | | |

| Inspection area 检验区域 | Inspection items 检验项目 | Inspection specifications 检验规格 | Defect category 缺陷类别 | |
|-------------------------|---|---|-------------------------|----|
| TP&CG | Point defects 点状不良 | 1. $D \leq 0.25\text{mm}$, Ignore (忽略) 2. $0.25\text{mm} < D \leq 0.50\text{mm}$; $N \leq 5$; $DS \geq 10\text{mm}$ 3. $0.50\text{mm} < D$, Not allowable (不允许) | | MI |
| | Scratches 划伤 | 1. $W \leq 0.10\text{mm}$; $L \leq 5\text{mm}$, Ignore (忽略) 2. $0.10\text{mm} < W \leq 0.15\text{mm}$; $L \leq 5\text{mm}$; $N \leq 5$; $DS \geq 10\text{mm}$ 3. $0.15\text{mm} < W$; $5\text{mm} < L$, Not allowable (不允许) 4. There is a feeling scratch, Not allowable 有感划伤, 不允许 | | MI |
| | Edges and corners cracked 崩角/崩边 | 1. Product front / 产品正面: Edge and corner chipping is not allowed 崩角、崩边不允许 2. Product back / 产品背面: $X \leq 0.5$, $Y \leq 0.5$, $Z \leq 1/2T$; $N \leq 5$; $DS \geq 10\text{mm}$ | | MI |
| | Silk screen 丝印 | The silk screen is clear, complete and correct 丝印清晰、完整、内容正确 | | MI |
| | Dirty 脏污 | Non-wipeable dirt, not allowed 不可擦拭的脏污, 不允许 | | MI |
| | Broken 破损 | Not allowable 不允许 | MA | |
| | Ink color aberration 油墨色差 | $\Delta E > 1$, Not allowable (不允许) | | MI |
| | Cover pinholes 针孔 | 1. $D \leq 0.20\text{mm}$, $N \leq 5$, $DS \geq 10\text{mm}$, allowable 2. $D > 0.20\text{mm}$, intensive pinholes (密集型针孔), Not allowable (不允许) | | MI |
| | IR holes IR孔 | Dirt, deviation, color difference, etc. are not allowed 不允许脏污、偏位、色差等 | | MI |
| BL 背光 | Backlight separation 背光分离 | Not allowable 不允许 | | MI |
| | Deformation of rubber iron and rubber frame 胶铁、胶框变形 | Use the plug gauge 0.3mm on the flat surface and can snap in and judge NG 在平面上使用塞规0.3mm卡翘曲位置, 能卡进判定NG | | MI |
| | The iron frame is oxidized and not tightened 铁框氧化、卡不紧 | Not allowable 不允许 | | MI |
| | Backlight sticky solder beads, glue, etc 背面粘锡珠、残胶等 | Not allowable 不允许 | | MI |
| | Inkjet coding, Barcode, QR code 喷码/条码/二维码 | The Inkjet coding is clear and complete, the barcode and QR code can be scanned normally, and the content and format match 喷码清晰完整、条码和二维码可正常扫描, 内容和格式相符 | | MI |
| | Accessories (protective film, double-sided tape, insulating adhesive, etc.) 辅料(保护膜、双面胶、绝缘胶等) | Defects such as missing pastes, sticking deviations, defects, and fractures are not allowed 不允许有漏贴、贴偏、残缺、断裂等缺陷 | | MI |

4.3 Electrical test specifications /电性检查规格

(D : diameter, W : width, L : length, N : quantity, DS : spacing)

| Inspection items 检验项目 | Inspection specifications 检验规格 | Defect category 缺陷类别 | |
|---|--|-------------------------|----|
| Glass bright spots/dark spots 玻璃亮点/暗点 | 1. $D \leq 0.25\text{mm}$, Ignore (忽略) 2. $0.25\text{mm} < D \leq 0.50\text{mm}$; $N \leq 5$; $DS \geq 10\text{mm}$ 3. $0.50\text{mm} < D$, Not allowable (不允许) | | MI |
| Mura | Use ND5% filter masking, visual invisibility is OK, 200~300Lux 使用ND5%遮盖, 目视不可见即为OK, 200~300Lux | | MI |
| Small bright dot 细碎亮点 | Use ND5% filter masking, visual invisibility is OK 使用ND5%遮盖, 目视不可见即为OK | | MI |
| Light leakage 漏光 | 1. Use ND5% filter masking, visual invisibility is OK 使用ND5%遮盖, 目视不可见即为OK 2. If necessary, sign off on the sample 必要时, 签限定样 | | MI |
| Backlight black/white dots 背光黑点/白点 | 1. $D \leq 0.25\text{mm}$, Ignore (忽略) 2. $0.25\text{mm} < D \leq 0.50\text{mm}$; $N \leq 5$; $DS \geq 10\text{mm}$ 3. $0.50\text{mm} < D$, Not allowable (不允许) | | MI |
| Linear foreign bodies 线状异物 (异物毛丝等) | 1. $W \leq 0.10\text{mm}$; $L \leq 5\text{mm}$, Ignore (忽略) 2. $0.10\text{mm} < W \leq 0.15\text{mm}$; $L \leq 5\text{mm}$; $N \leq 5$; $DS \geq 10\text{mm}$ 3. $0.15\text{mm} < W$; $5\text{mm} < L$, Not allowable (不允许) | | MI |
| Black/White Print 黑印/白印 | Use ND5% filter masking, visual invisibility is OK 使用ND5%遮盖, 目视不可见即为OK | | MI |
| The display is uneven 显示不均匀 | Use ND5% filter masking, visual invisibility is OK 使用ND5%遮盖, 目视不可见即为OK | | MI |
| The brightness is uneven 亮度不均匀 | Brightness uniformity $< 85.0\%$, Not allowable 亮度均匀性 $< 85.0\%$, 不允许 | | MI |
| Displacement of the membrane 膜材移位 | Not allowable 不允许 | | MI |
| Interference pattern/Newtonian pattern 干涉纹/牛顿纹 | Not allowable 不允许 | | MI |
| Display abnormal 显示异常 | Not allowable 不允许 | MA | |
| No display 无显示 | Not allowable 不允许 | MA | |
| Line/Missing Drawing 线条/缺画 | Not allowable 不允许 | MA | |
| Splash screen 闪屏 | Not allowable 不允许 | MA | |
| LCD grid LCD网格 | Not allowable 不允许 | MA | |
| Afterimage 残影 | Not allowable 不允许 | MA | |
| Wrong viewing angle 视角错误 | Not allowable 不允许 | MA | |
| No touch 无触摸 | Not allowable 不允许 | MA | |
| Touch the jump point 触摸跳点 | Not allowable 不允许 | MA | |
| Not sensitive 触摸不灵敏 | Not allowable 不允许 | MA | |