

# Shenzhen Leadtek Electronics Co.,Ltd

## PRODUCT SPECIFICATION

### TFT-LCD HDMI MODULE

**Module No:** LTK068WSBHT10-V0

Preliminary Specification

Approval Specification

Designed by	Checked by	Approved by
<i>jona</i>	<i>Jerry</i>	<i>lan</i>

### Final Approval by Customer

Approved by	Comment

The specification of "TBD" should refer to the measured value of sample . If there is difference between the design specification and measured value, we naturally shall negotiate and agree to solution with customer.





# Front View

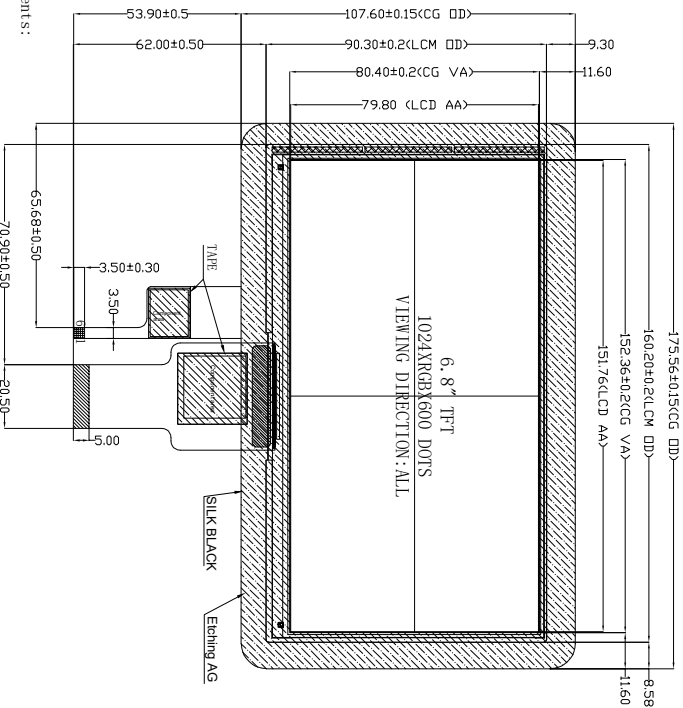

# Side View

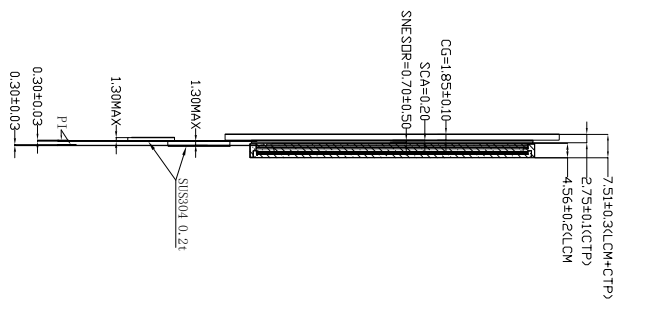

# Back View

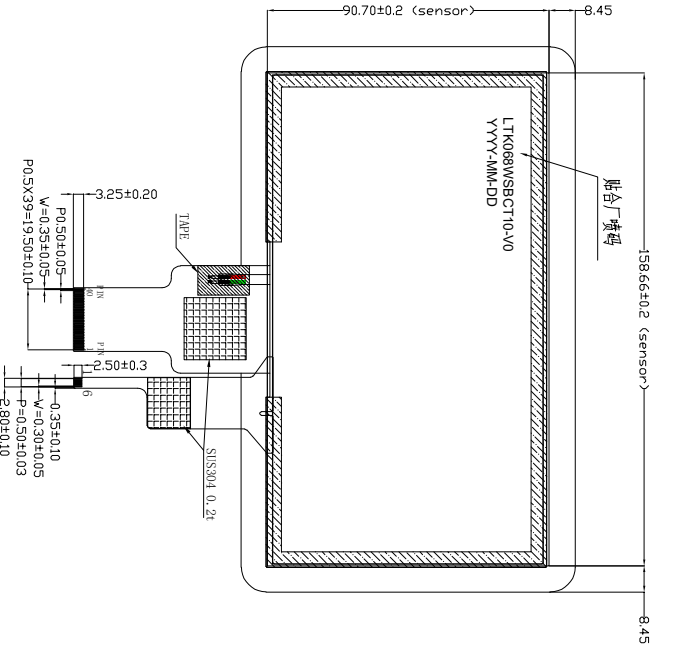

PIN	DESCRIPTION
1	NC
2	VDD=3.3V
3	VDD=3.3V
4	NC
5	RESET
6	STBYB
7	GND
8	RX1NO-
9	RX1NO+
10	GND
11	RX1NI-
12	RX1NI+
13	GND
14	RX1N2-
15	RX1N2+
16	GND
17	RXC1KN-
18	RXC1KN+
19	GND
20	RX1N3-
21	RX1N3+
22	GND
23~24	NC
25	GND
26~27	NC
28	SELB
29	NC
30	GND
31~32	LED-
33	SHLR
34	UPDN
35	NC
36~37	NC
38	NC
39~40	LED+

- Technical requirements:
1. structure: G+G,
  2. transmittance:  $\geq 85\%$ ,
  3. All unmarked tolerance:  $\pm 0.15\text{mm}$ ,
  4. IG: FT7311
  5. Toughened degrees: 110g steel ball, 40cm drop height is not broken, surface hardness Test:  $\geq 6H$  (pencil hardness test)
  6. CG unmarked hole and edge  $\leq 0.20\text{mm}$
  7. operate temperature:  $-30^{\circ}\text{C} \sim 80^{\circ}\text{C}$ ; storage temperature:  $-30 \sim 80^{\circ}\text{C}$ ;
  8. All material compliant with ROHS.

- Notes:
1. Display : 6.8", TFT
  2. Resolution: 1024xRGBx600
  3. LCD Viewing Direction: ALL,
  4. Drive IC: JD9168
  5. Display Mode: Normally Black/Transmissive
  6. LCM Brightness: 850cd/m<sup>2</sup> (TYP)
  7. LCM+CTP Brightness: 800cd/m<sup>2</sup> (TYP), uniformity  $\geq 80\%$
  8. umark Tolerance:  $\pm 0.2$
  9. OPERATING TEMP:  $-30^{\circ}\text{C} \sim +80^{\circ}\text{C}$
  10. STORAGE TEMP:  $-30^{\circ}\text{C} \sim +80^{\circ}\text{C}$
  10. Requirements on Environmental Protection: ROHS

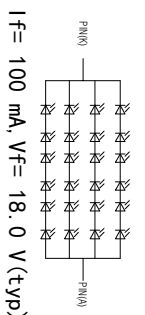

I<sub>F</sub> = 100 mA, V<sub>F</sub> = 18.0 V (typ)

CTP PIN	Definition
PN1	GND
PN2	SCL-1.8V
PN3	SDA-1.8V
PN4	INT-1.8V
PN5	RESET-1.8V
PN6	VCC-3.3V

**LEADTEK DISPLAY**

**LEADTEK COMPANY LIMITED**

SCALE: 1/1 UNIT: mm PAGE: 1/1

Part No.: LTK068WSBCT10 VER: V0

Customer No.: IAN

DATE: 2022.07.27 JCCK

DESCRIPTION: NEW

REV	DESCRIPTION	DATE	NAME
0			
1			
2			
3			
4			
5			
6			

APPROVE	CHECK	DRAWN
IAN	JOMA	JCCK

## 5.0 Interface Pin Connection

(Input signal): FPC Down Connector, (FH19SC-60S-0.5SH (HIROSE), 50pin, pitch = 0.5mm)

Pin No.	Symbol	I/O	Function	Remark
1	NC	P	No connection	
2	VDD	P	Power Voltage for digital circuit	
3	VDD	P	Power Voltage for digital circuit	
4	NC	---	No connection	
5	Reset	I	Global reset pin	
6	STBYB	I	Standby mode, Normally pulled high STBYB = "1", normal operation STBYB = "0", timing controller, source driver will turn off, all output are High-Z	
7	GND	P	Ground	
8	RXIN0-	I	- LVDS differential data input	
9	RXIN0+	I	+ LVDS differential data input	
10	GND	P	Ground	
11	RXIN1-	I	- LVDS differential data input	
12	RXIN1+	I	+ LVDS differential data input	
13	GND	P	Ground	
14	RXIN2-	I	- LVDS differential data input	
15	RXIN2+	I	+ LVDS differential data input	
16	GND	P	Ground	
17	RXCLKIN-	I	- LVDS differential clock input	
18	RXCLKIN+	I	+ LVDS differential clock input	
19	GND	P	Ground	
20	RXIN3-	I	- LVDS differential data input	
21	RXIN3+	I	+ LVDS differential data input	
22	GND	P	Ground	
23	NC	---	No connection	
24	NC	---	No connection	
25	GND	P	Ground	
26	NC	---	No connection	

27	NC	---	No connection	
28	SELB	I	6bit/8bit mode select	Note1
29	NC	P	No connection	
30	GND	P	Ground	
31	LED-	P	LED Cathode	
32	LED-	P	LED Cathode	
33	L/R	I	Horizontal inversion	Note3
34	U/D	I	Vertical inversion	Note3
35	NC	P	No connection	
36	NC	P	No connection	
37	NC	P	No connection	
38	NC	P	Gate ON Voltage	
39	LED+	P	LED Anode	
40	LED+	P	LED Anode	

Note() Selection of scanning mode (please refer to the following table)

Setting of scan control input		IN/OUT state for start pulse				Scanning direction
U/D	L/R	STVD	STVU	STHR	STHL	
GND	DVDD	Output	input	output	input	up to down, and from left to right
DVDD	GND	input	output	input	output	down to up, and from right to left
GND	GND	output	input	input	output	up to down, and from right to left
DVDD	DVDD	input	output	output	input	down to up, and from left to right

Note() MOD=H: Simultaneous sampling.(Please check CPH2 and CPH3 to GND when MOD=H)

MOD=L: Sequential sampling.

## 2.0 Absolute Maximum Ratings

### 2.1 Electrical Absolute Rating

Parameter	Symbol	Min.	Max.	Unit	Note
Power supply voltage	VCC	-0.3	+3.6	V	GND=0
	IOVCC	+0.3	+3.3	V	GND=0

### 2.2 Environment Absolute Rating

Item	Symbol	Min.	Max.	Unit	Note
Operating Temperature	Topa	-30	80		
Storage Temperature	Tstg	-30	80		

### 2.3 Back-light Unit:

PARAMETER	Sym.	Min.	Typ.	Max.	Unit	Test Condition	Note
LED Current	IF	-	100	-	mA	-	-
LED Voltage	VF	-	18	-	V	I=100mA	-
Life Time		-	30000	-	Hr.	I 100mA	-
Brightness	Luminance	-	8€0	--	cd/m2	I=100mA	
Color	White						

Note (1) Permanent damage may occur to the LCD module if beyond this specification. Functional operation should be restricted to the conditions described under normal operating conditions.

(2)  $T_a = 25 \pm 2$

(3) Test condition: LED Current 100mA

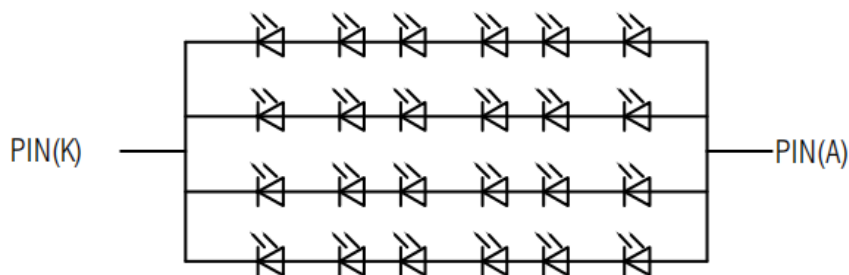

$$I_f = 100 \text{ mA}, V_f = 18.0 \text{ V (typ)}$$

### 3.0 OPTICAL CHARACTERISTICS

#### 3.1 Optical Specification

Viewing Angle		Horizontal	Vertical	CR	A	H	A	I	F
Viewing Angle	Horizontal	$\Theta_3$	CR > 10	CR > 10	80	85	-	Deg.	Note 1
		$\Theta_9$			80	85	-	Deg.	
	Vertical	$\Theta_{12}$			80	85	-	Deg.	
		$\Theta_6$			80	85	-	Deg.	
Cell Transmittance					3.6	4.75		%	
Contrast ratio		CR			800:1	1000:1	-		Note 2
Reproduction of color	White	$W_x$	$\Theta = 0^\circ$ (Center) Normal Viewing Angle	TYP. - 0.03	TYP. + 0.03	-	-	0.309	Note 3
		$W_y$						0.348	
	Red	$R_x$						-	
		$R_y$						-	
	Green	$G_x$						-	
		$G_y$						-	
	Blue	$B_x$						-	
		$B_y$						-	
Color Gamut					50	55	-	% NTSC	
Response Time		Tr+Td			-	30	35	ms	Note 4
Gamma Scale					1.9	2.2	2.5		

### 4.Features

#### 4.1,Support HDMI

VGA(Common resolutions: 640\*480,800\*480,800\*600,1024\*600,1024\*768, 1280\*800, CVBS

#### 4.2,Input Voltage :DC +12V (9V-15V)

4.3, Multi-function OSD, support brightness, contrast and pareter adjustment

4.4,Support remote control function

4.5,Power-on and power-off indicator status



## 6. External drawing

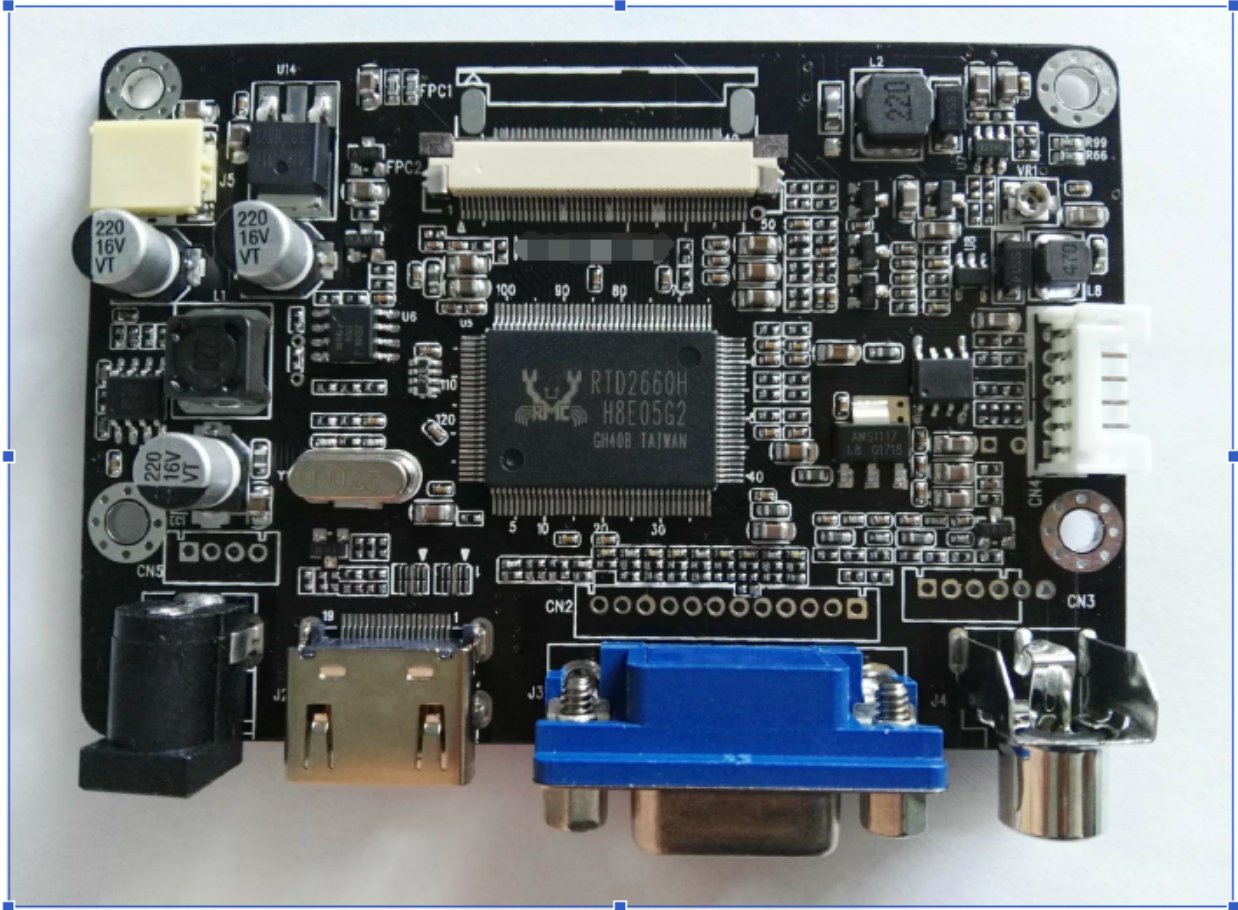

## 7. Electrical Circuit

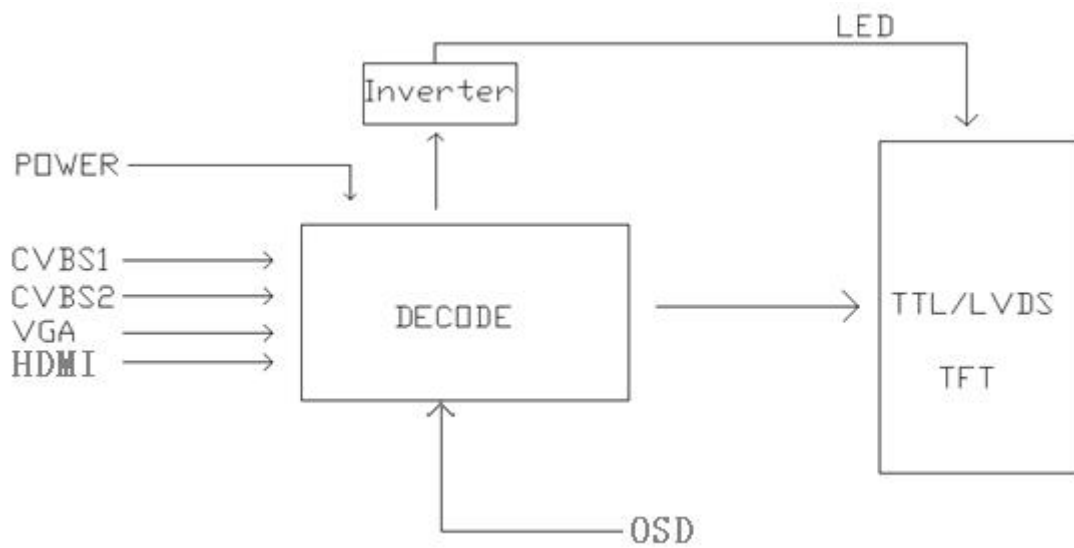

## 8. Interface Definition

power supply J1 (DC-2.1-005)

power supply CN1/CN5

Foot number	Definition	Describe
1	+12V	power
2	+12V	power
3	GND	land
4	GND	land

J2, HDMI

J3 VGA Interface (VGA-15P-3.08)

CN2 VGA Interface

Pin number	Definition	Describe
1	SCL	I2C
2	SDA	I2C
3	GND	land

4	B+	blue signal+
5	GND	land
6	G+	green signal+
7	GND	land
8	R+	red signal+
9	GND	land
10	HS	line sync signal
11	VS	field sync signal
12	GND	land

### Signal input CN3

Foot number	Definition	Describe
1	CVBS2	AV2 enter
2	GND	land
3	CVBS1	AV1 enter
4	GND	land
5	ACC	Reversing detection12V (5V-16V)
6	GND	

### Keypad Interface CN4

Foot number	Definition	Describe
1	VCC +3.3V	key board power
2	GND	land
3	IR INT	Infrared acceptance
4	KEY	Keypad AD interface
5	LED RED	Keypad LED
6	LED GREEN	Keypad LED

## - .Reliability test items

No.	Test Item	Test Condition	Notes
1	High Temp. Storage	+80°C / 48H	1. Functional test isOK. Missing Segment,short, unclear segment non-display,display abnormally and liquid crystal leakare un-allowed. 2. No low temperature bubbles,end seal loose andfall, frame rainbow.
2	Low Temp. Storage	-30°C / 48H	
3	High Tempe. Operating	+80°C / 48H	
4	Low Tempe. Operating	-30°C / 48H	
5	High Temperature /Humidity storage	50°C x 90%RH /48H	
6	Thermal and cold shock	Static state, -20°C (30min) ~60°C (30min), 50 cycles	
7	ESD test	±2KV,Human Body Mode, 150pF/330Ω; ±4KV, Air Mode, 150pF/330Ω;	

Note: All tests above are practiced at module type.

There is no display function NG issue occurred, All the cosmetic specification is judged before the reliability stress.

## 10. General Precaution

### 10.1 Use Restriction

This product is not authorized for use in life supporting systems, aircraft navigation control systems, military systems and any other application where performance failure could be life-threatening or otherwise catastrophic.

### 10.2 Assembly Precaution

- 1、 Please use the mounting hole on the module side in installing and do not bending or wrenching LCD in assembling. And please do not drop, bend or twist LCD module in handling.
- 2、 Please design display housing in accordance with the following guide lines.
- 3、 Housing case must be destined carefully so as not to put stresses on LCD all sides and not to wrench module. The stresses may cause non-uniformity even if there is no non-uniformity statically.
- 4、 Keep sufficient clearance between LCD module back surface and housing when the LCD module is mounted. The clearance in the design is recommended taking into account the tolerance of LCD module thickness and mounting structure height on the housing.
- 5、 Please do not push or scratch LCD panel surface with any-thing hard. And do not soil LCD panel surface by touching with bare hands. (Polarizer film, surface of LCD panel is easy to be flawed.)
- 6、 Please do not press any parts on the rear side such as source IC, gate IC, and FPC during handling LCD module. If pressing rear part is unavoidable, handle the LCD module with care not to damage them.
- 7、 Please wipe out LCD panel surface with absorbent cotton or soft cloth in case of it being soiled.
- 8、 Please wipe out drops of adhesives like saliva and water on LCD panel surface immediately. They might damage to cause panel surface variation and color change. 11.2.7 Please do not take a LCD module to pieces and reconstruct it. Resolving and reconstructing modules may cause them not to work well.

### 10.3 Disassembling or Modification

Do not disassemble or modify the module. It may damage sensitive parts inside LCD module, and may cause scratches or dust on the display. Leadtek does not warrant the module, if customers disassemble or modify the module.

### 10.4 Breakage of LCD Panel

- 1、 If LCD panel is broken and liquid crystal spills out, do not ingest or inhale liquid crystal, and do not contact liquid crystal with skin.
- 2、 If liquid crystal contacts mouth or eyes, rinse out with water immediately.
- 3、 If liquid crystal contacts skin or cloths, wash it off immediately with alcohol and rinse thoroughly with water.
- 4、 Handle carefully with chips of glass that may cause injury, when the glass is broken.

## 10.5 Absolute Maximum Ratings and Power Protection Circuit

- 1、 Do not exceed the absolute maximum rating values, such as the supply voltage variation, input voltage variation, variation in parts' parameters, environmental temperature, etc., otherwise LCD module may be damaged.
- 2、 Please do not leave LCD module in the environment of high humidity and high temperature for a long time.
- 3、 It's recommended employing protection circuit for power supply.

### 11.6 Operation

- 1、 Do not touch, push or rub the polarizer with anything harder than HB pencil lead. Use fingerstalls of soft gloves in order to keep clean display quality, when persons handle the LCD module for incoming inspection or assembly.
- 2、 When the surface is dusty, please wipe gently with absorbent cotton or other soft material.
- 3、 Wipe off saliva or water drops as soon as possible. If saliva or water drops contact with polarizer for a long time, they may causes deformation or color fading.
- 4、 When cleaning the adhesives, please use absorbent cotton wetted with a little petroleum benzine or other adequate solvent.

## 10.6 Static Electricity

- 1、 Protection film must remove very slowly from the surface of LCD module to prevent from electrostatic occurrence.
- 2、 Because LCD module uses CMOS-IC on TFT-LCD panel, it is very weak to electrostatic discharge. Please be careful with electrostatic discharge.
- 3、 Persons who handle the module should be grounded through adequate methods.

## 10.7 Disposal

When disposing LCD module, obey the local environmental regulations.

## 10.8 OTHERS

- 1、 A strong incident light into LCD panel might cause display characteristics' changing inferior because of polarizer film, color filter, and other materials becoming inferior. Please do not expose LCD module direct sunlight land strong UV rays.
- 2、 Please pay attention to a panel side of LCD module not to contact with other materials in preserving it alone.
- 3、 For the packaging box, please pay attention to the followings:
- 4、 Packaging box and inner case for LCD are designed to protect the LCDs from the damage or scratching during transportation. Please do not open except picking LCDs up from the box.
- 5、 Please do not pile them up more than 6 boxes. (They are not designed so.) And please do not turn over.
- 6、 Please handle packaging box with care not to give them sudden shock and vibrations. And also please do not throw them up.
- 7、 Packing box and inner case for LCDs are made of cardboard. So please pay attention not to get them wet. (Such like keeping them in high humidity or wet place can occur getting them wet.)

## 11.0 Packing form-TBD



## 1.Scope 1适用范围

This document shall be applied to 5.0~9.0 TFT-LCD Panel.

本文件适用于5.0~9.0 TFT-LCD Panel.

## 2.Inspection and Environment onditions/检查条件与环境

### 2.1 Inspection Conditions 检查条件:

(1) Inspection Distance检测距离: 35 cm±5cm

(2) Each picture /每个画面: 2~3 secs/秒, Cosmetic Insp./外观10~12 secs/秒

(3) View Angle观看角度:

Light-on Inspection Angle点灯检验角度 : ±45°

Cosmetic Inspection Angle外观检验角度 : ±45°

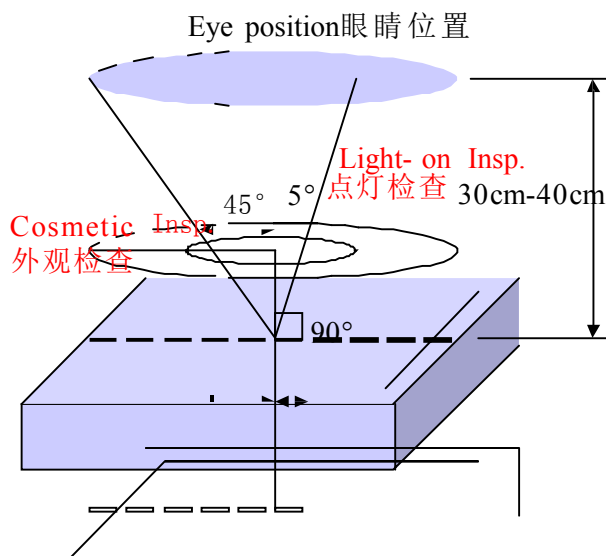

(Perpendicular to LCD panel surface垂直于液晶显示表面)

### 2.2 Environment Conditions环境条件:

Ambient Temperature 温度		25°C±5°C
Ambient Humidity 湿度		55±5%RH
Ambient Illumination 亮度	Cosmetic Inspection 外观检验	800-1000 Lux
	Functional Inspection 点灯检验	200~300Lux

### 2.3 Sampling Conditions 抽样条件:

(1) Lot Size : Quantity of shipment lot per model/.

批量: 单次运送单一机型数量

- (2) Sampling Method :  
抽样方法:

Sampling Plan 抽样计划		GB2828/2003
		Normal Inspection, Single Sampling 正常检验、单次抽样
		Geneal II Inspection 普通二级
AQL	Major Defect 主要缺点	0.25
	Minor Defect 次要缺点	0.65

- (3) The classification of Major(MA) and Minor(MI) defects is shown as 3. Inspection Criteria.  
主缺(MA)及次缺(MI)定义于”3.检查标准”

### 3. Terms and Definitions/术语和定义

#### 3.1 Classification of defects缺陷的分类:

Major defects: A major defect is a defect that is likely to result in failure, or to reduce materially the usability of the product for its intended purpose.

主要缺陷：会导致产品功能失效或减少产品可用性的缺陷。

Minor defects: A minor defect either is a defect that is not likely to reduce materially the usability of the product for its intended purpose, or is a departure from an established having little bearing on the effective use or operation of the product.

次要缺陷：不会导致产品功能失效，不会减少产品的有效使用和操作。

- 3.2 Extraneous substances that can be wiped out ,like Finger point,Particles are not considered as a defect . 可以被擦拭干净的表面物质不视为缺陷 (如手指印, 尘粒)。

- 3.3 Defects on the Black Matraix(outside of Active Area) are not considered as a defect . BM 区域 (AA 区以外) 的缺陷不视为缺陷。

- 3.4 Size of circular defect,is defined by diameter”D” 。 The defect average diameter  $D=1/2(W+L)$  圆形缺陷的大小是由直径 D 定义的。缺陷的平均直径  $D=1/2(W+L)$

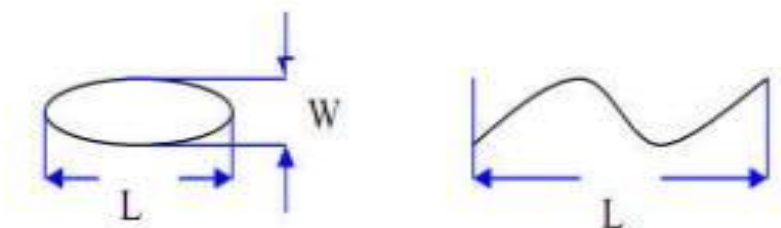

3.5 When defect size  $L \geq 2W$ , the defect count as liner type defect. Size of linear defect is defined by length(L) and the maximum width(W).

当缺陷尺寸  $L \geq 2W$  时，被视为线状缺陷。线状缺陷是由长度 (L) 和最大宽度 (W) 定义的。3.6 Mura criteria :judged by ND filter 6%, and can't be seen under at ND filter 6% .

3.6 MURA 判断标准：使用 ND6% 判定，且透过 ND6%，遮住不可见。

3.7 Dot defect is defined as the defective area of the dot is larger than 50% of the dot area and is visible through 6% ND filter

DOT 定义为点缺陷面积大于 50% DOT 面积，且透过 ND6% 遮住是可见的。

The drawing of 1/2 area sub-pixel definition: The 1/2 area sub-pixel can be defined as below one or more of specific shapes

1/2 面积的子像素定义绘图：1 / 2 面积的子像素可以定义为如下一个或多个特定形状图：



3.8 A dot defect that is smaller than the defined dot defect will be treated as small bright dot. 细碎亮点：小于“DOT 定义”的点缺陷视为细碎亮点。

I 区与 O 区比例：1: 2: 1

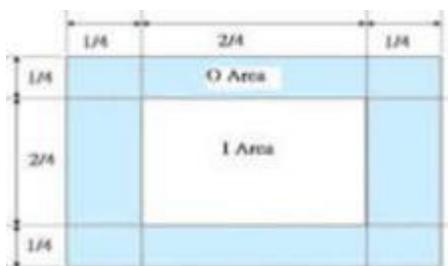

3.9 Inspection method of ND Filter - holding ND filter in front of the panel around 5cm and examine the panel from 35±5 cm in the front view for 2~3 second.

ND 卡的检查方法：在面板上方大约 5CM 处握住 ND 卡，眼睛距离面板 30-40CM，通过 2~3 秒观察。

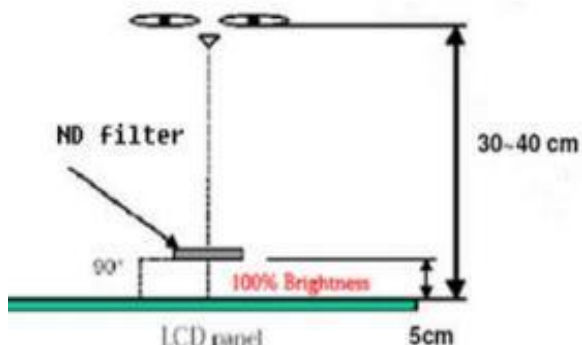

## 4. Inspection Criteria 检验标准

### 4.1 Appearance Inspection specification 外观检查规格:

Judge area 区域	Judge item 项目	Specification inspection 检查规格	Judge criterion	
			Major	Minor
Silicone 硅胶	Silicone spread 硅胶涂布	The height can't over C/F , color filter , or gomou 高度不能过超 C/F		MI
	Silicone residue 硅胶残余	Can't cover polarizer, FPC ...etc. 不能覆盖 POL, FPC 等		MI
LCD 玻璃	Wire(on Array) 线路	No damage 不能损伤	MA	
	Edge 边缘	No extended crack 不可有延伸性裂纹	MA	
PCBA Connector FPC/FFC	Appearance 外观	Scratch or damage result in copper expose is not allowed 划伤或损伤不允许导致出现露铜		MI
	Component 零件	No damage 不能损伤	MA	
	Connection status 连接状况	Need correct connection 需要正确连接	MA	
	Broken 破裂	Not allowable 不允许	MA	
	Folding sign 对位记号折叠	Not allowable 不允许	MA	
POL 偏光片	Scract on the polarizer 偏光片划伤	1. $W \leq 0.07\text{mm}$ ; $L \leq 5\text{mm}$ , Ignore (忽略)		MI
		2. $0.07\text{mm} < W \leq 0.15\text{mm}$ ; $L \leq 5\text{mm}$ ; $N \leq 4$ ; $DS \geq 10\text{mm}$		
		3. $15\text{mm} < W$ ; $5\text{mm} < L$ , Not allowable不允许		

Judge area 区域	Judge item 项目	Specification inspection 检查规格	Judge criterion	
			Major	Minor
POL 偏光片	Dent on the polarizer 偏光片凹痕	1.D<0.20mm, Ignore (忽略)		MI
		2.0.20mm<D≤0.40mm; N≤4; DS≥10mm		
		3.0.40mm<D, Not allowable不允许		
	POL Linear bubble 线状气泡	1.W≤0.07mm; L≤5mm, Ignore (忽略)		MI
		2.0.07mm<W≤0.15mm ; L≤5mm ; N≤4 ; DS≥10mm		
		3.0.15mm<W; 5mm< L , Not allowable不允许		
	POL dot bubble 点状气泡	1.D<0.20mm, Ignore (忽略)		MI
		2.0.20mm<D≤0.40mm; N≤4; DS≥10mm		
		3.0.40mm<D, Not allowable不允许		
	POL edge bubble 片边缘气泡	1. The display area is 1/2BM outside, Not allowable 显示区往外 1/2BM 区域内, 不允许  2. The display area is outside the outer 1/2BM area, Not allowable 显示区往外1/2BM区域以外, 不管控		MI

Judge area 区域	Judge item 项目	Specification inspection 检查规格	Judge criterion	
			Major	Minor
TP&CG	Foreign Material in spot shape 点状异物	1.D≤0.20mm; Ignored (忽略) 2.0.20mm<D≤0.40mm; N≤4; DS≥10mm 3.D>0.40mm; Not allowable不允许		MI
	Fisheye/bubbles 鱼眼/气泡	1.D≤0.20mm; Ignored (忽略) 2.0.20mm<D≤0.40mm; N≤4; DS≥10mm 3.D>0.40mm; Not allowable不允许		MI
	Scratches on the surface 表面划伤	1.W≤0.07mm; Ignored (忽略) 2.0.07mm<W≤0.15mm, L≤5mm; N≤4; DS≥10mm 3.W>0.15mm, L>5mm; Not allowable不允许		MI
	Collapse corner、Crash edge 崩角、崩边	Product front:/产品正面: collapse corners, collapsed edges are not allowed 崩角、崩边不允许; Product back/产品背面: X≤0.5, Y≤0.5, Z≤1/2T; N≤4; DS≥10mm	MA	
	Printed fonts/LOGO 丝印/LOGO	Printed fonts/LOGO clarity、complete、content right 字体/LOGO丝印清晰、完整、内容正确		MI
	Broken 破损	Not allowable不允许	MA	
	Dirty surfaces 表面脏污	Dirt cannot be wiped, Not allowable 不可擦拭的脏污, 不允许		MI
	IR hole IR孔	Black spots/黑点: W ≤0.15mm, N≤2, Not visible against a black background/黑色背景下不可见		MI
IR hole Scratches: 1.W<0.05mm, Ignored (忽略) (Dense points Not allowable 不允许密集); 2.0.05mm<W≤0.07mm; L≤2mm; N≤2; 3.W>0.07mm, L>2mm, Not allowable 不允许			MI	

## 4.2 Electrical Inspection specification 电性检查规格:

Item 项目	Judgment Criteria 判定标准	Judge criterion	
		Major	Minor
LCD Bright /Dark dot 玻璃亮点/暗点	1.D $\leq$ 0.20mm, Ignored (忽略), Not dense (不可密集) 2.0.20mm<D $\leq$ 0.40mm; N $\leq$ 4; DS $\geq$ 10mm 3.D>0.40mm, Not allowed/不允许		MI
Mura	Invisible through 6% ND filter, 200~300Lux 透过ND6% 遮住, 目测不可见即为OK, 200~300Lux		MI
Small bright dot 细碎亮点	Not allowed if it can be observed through ND Filter6% 透过ND6%目测看得见, 不允许		MI
ZBD Rate 玻璃亮点比率	90:10		MI
Light Leakage 漏光	Invisible through 6% ND filter, OK 透过ND6%遮住目测不可见即为OK If necessary,set up set up Limit Sample. 如果有必要, 可制订限度样品		MI
Bubble in Cell (LC Bubble/Actice Area) CELL气泡 (AA区LCD气泡)	Eyes should not find it . 目视观察不可见, 视为 OK	MA	

Item 项目	Judgment Criteria 判定标准	Judge criterion	
		Major	Minor
Foreign Material in spot shape 点状异物	1. $D \leq 0.20\text{mm}$ , Ignored (忽略) 2. $0.20\text{mm} < D \leq 0.40\text{mm}$ ; $N \leq 4$ ; $DS \geq 10\text{mm}$ 3. $D > 0.40\text{mm}$ , Not allowable/不允许		MI
Foreign Material in line or spiral shape 线状异物	1. $W \leq 0.07\text{mm}$ , Ignored (忽略) 2. $0.07\text{mm} < W \leq 0.15\text{mm}$ ; $L \leq 5\text{mm}$ ; $N \leq 4$ 3. $W > 0.15\text{mm}$ ; $L > 5\text{mm}$ , Not allowable/不允许		MI
White dot in back-light 白点	1. $D \leq 0.20\text{mm}$ , Ignored (忽略) 2. $0.20\text{mm} < D \leq 0.40\text{mm}$ ; $N \leq 4$ ; $DS \geq 10\text{mm}$ 3. $D > 0.40\text{mm}$ , Not allowed/不允许		MI
TP no touch 无触摸	Not allowable 不允许	MA	
Abnormal Disply 显示异常	Not Allowed 不允许	MA	
NO display 无显示	Not Allowed 不允许	MA	
Line Defect 缺线	Not Allowed 不允许	MA	
Angle of view error 视角错误	Not Allowed 不允许	MA	
Tect crostalk 不消失的残影	Not Allowed 不允许	MA	